

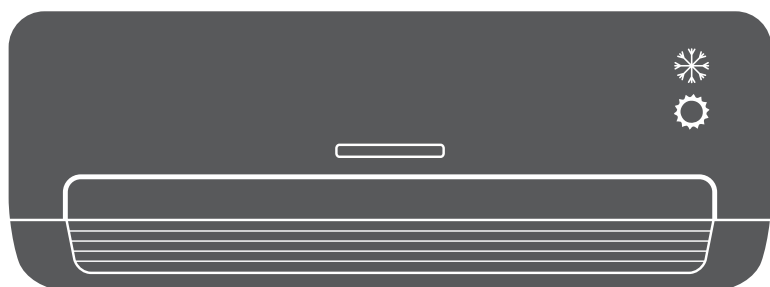

## AIR CONDITIONING SYSTEMS

### WALL MOUNTED UNIT

#### • SERVICE MANUAL



#### MODELS:

P9MVI32-09WiFi / P9MVO32-09  
P9MVI32-12WiFi / P9MVO32-12  
P9MVI32-18WiFi / P9MVO32-18  
P9MVI32-24WiFi / P9MVO32-24





# CONTENTS

<b>1. Precaution</b> .....	<b>2</b>
1.1 Safety Precaution .....	2
1.2 Warning .....	2
<b>2 Information servicing</b> .....	<b>4</b>
<b>3. Model list</b> .....	<b>10</b>
<b>4. Dimension</b> .....	<b>11</b>
4.1 Indoor Unit .....	11
4.2 Outdoor Unit .....	14
<b>5. Refrigerant Cycle Diagram</b> .....	<b>18</b>
<b>6 Installation Details</b> .....	<b>19</b>
6.1 Wrench torque sheet for installation .....	19
6.2 Connecting the cables .....	19
6.3 Pipe length and the elevation .....	20
6.4 Installation for the first time .....	21
6.5 Adding the refrigerant after running the system for many years .....	22
6.6 Re-installation while the indoor unit need to be repaired .....	22
6.7 Re-installation while the outdoor unit need to be repaired .....	25
<b>7. Disassemble Guide</b> .....	<b>26</b>
<b>8. Wiring Diagram</b> .....	<b>32</b>
8.1 Indoor Unit .....	32
8.2 Outdoor Unit .....	33
<b>9. Operation Characteristics</b> .....	<b>34</b>
<b>10. Electronic function</b> .....	<b>35</b>
10.1 Abbreviation .....	35
10.2 Display function .....	35
10.3 Main Protection .....	36
10.4 Operation Modes and Functions .....	37
10.5 Multi-function board instruction (This multi-function board is optional) .....	45
<b>11. Troubleshooting</b> .....	<b>48</b>
11.1 Indoor Unit Error Display .....	49
11.2 Trouble shooting .....	50



**Caution: Risk of fire/flammable materials**

# 1. Precaution

## 1.1 Safety Precaution

■ To prevent injury to the user or other people and property damage, the following instructions must be followed.

■ Incorrect operation due to ignoring instruction will cause harm or damage.

■ Before service the unit, be sure to read this service manual at first.

## 1.2 Warning

➤ Appliance shall be stored in a room without continuously operating open flames (for example an operating gas appliance) and ignition sources (for example an operating electric heater).

➤ Installation

■ Do not install the unit at place where leakage of flammable gas may occur. In case gas leaks and accumulates at surrounding of the unit, it may cause fire.

■ Do not use a defective or underrated circuit breaker. Use this appliance on a dedicated circuit.

There is risk of fire or electric shock.

■ For electrical work, contact the dealer, seller, a qualified electrician, or an authorized service center.

Do not disassemble or repair the product, there is risk of fire or electric shock.

■ Always ground the product.

There is risk of fire or electric shock.

■ Install the panel and the cover of control box securely.

There is risk of fire of electric shock.

■ Always install a dedicated circuit and breaker.

Improper wiring or installation may cause fore or electric shock.

■ Use the correctly rated breaker of fuse.

There is risk of fire or electric shock.

■ Do not modify or extend the power cable.

There is risk of fire or electric shock.

■ Do not install, remove, or reinstall the unit by yourself (customer).

There is risk of fire, electric shock, explosion, or injury.

■ Be caution when unpacking and installing the product.

Sharp edges could cause injury, be especially careful of the case edges and the fins on the condenser and evaporator.

■ For installation, always contact the dealer or an authorized service center.

■ Do not install the product on a defective installation stand.

■ Be sure the installation area does not deteriorate with age.

If the base collapses, the air conditioner could fall with it, causing property damage, product failure, and personal injury.

■ Do not let the air conditioner run for a long time when the humidity is very high and a door or a window is left open.

■ Take care to ensure that power cable could not be pulled out or damaged during operation.

There is risk of fire or electric shock.

■ Do not place anything on the power cable.

There is risk of fire or electric shock.

■ Do not plug or unplug the power supply plug during operation.

There is risk of fire or electric shock.

■ Do not touch (operation) the product with wet hands.

- **Do not place a heater or other appliance near the power cable.**

There is risk of fire and electric shock.

- **Do not allow water to run into electrical parts.**

It may cause fire, failure of the product, or electric shock.

- **Do not store or use flammable gas or combustible near the product.**

There is risk of fire or failure of product.

- **Do not use the product in a tightly closed space for a long time.**

Oxygen deficiency could occur.

- **When flammable gas leaks, all naked flames shall be removed or extinguished.**

- **If strange sounds or smoke comes from product, turn the breaker off or disconnect the power supply cable.**

There is risk of electric shock or fire.

- **Stop operation and close the window in storm or hurricane. If possible, remove the product from the window before the hurricane arrives.**

There is risk of property damage, failure of product, or electric shock.

- **Do not open the inlet grill of the product during operation. (Do not touch the electrostatic filter, if the unit is so equipped.)**

There is risk of physical injury, electric shock, or product failure.

- **When the product is soaked, contact an authorized service center.**

There is risk of fire or electric shock.

- **Be caution that water could not enter the product.**

There is risk of fire, electric shock, or product damage.

- **Ventilate the product from time to time when operating it together with a stove etc.**

There is risk of fire or electric shock.

- **Turn the main power off when cleaning or maintaining the product.**

There is risk of electric shock.

- **When the product is not be used for a long time, disconnect the power supply plug or turn off the breaker.**

There is risk of product damage or failure, or unintended operation.

- **Take care to ensure that nobody could step on or fall onto the outdoor unit.**

This could result in personal injury and product damage.

➤ **CAUTION**

- **Always check for gas (refrigerant) leakage after installation or repair of product.**

Low refrigerant levels may cause failure of product.

- **Install the drain hose to ensure that water is drained away properly.**

A bad connection may cause water leakage.

- **Keep level even when installing the product.**

It can avoid vibration of water leakage.

- **Do not install the product where the noise or hot air from the outdoor unit could damage the neighborhoods.**

It may cause a problem for your neighbors.

- **Use two or more people to lift and transport the product.**

- **Do not install the product where it will be exposed to sea wind (salt spray) directly.**

It may cause corrosion on the product. Corrosion, particularly on the condenser and evaporator fins, could cause product malfunction or inefficient operation.

➤ **Operational**

- **Do not expose the skin directly to cool air for long time. (Do not sit in the draft).**

- **Do not use the product for special purposes, such as preserving foods, works of art etc. It is a consumer air conditioner, not a precision refrigerant system.**

There is risk of damage or loss of property.

- **Do not block the inlet or outlet of air flow.**

- **Use a soft cloth to clean. Do not use harsh detergents, solvents, etc.**

There is risk of fire, electric shock, or damage to the plastic parts of the product.

- **Do not touch the metal parts of the product when removing the air filter. They are very sharp.**

- **Do not step on or put anything on the product. (outdoor units)**

- **Always insert the filter securely. Clean the filter every two weeks or more often if necessary.**

A dirty filter reduces the efficiency of the air conditioner and could cause product malfunction or damage.

- **Do not insert hands or other objects through air inlet or outlet while the product is operated.**

- **Do not drink the water drained from the product.**

- **Use a firm stool or ladder when cleaning or maintaining the product.**

Be careful and avoid personal injury.

- **Replace the all batteries in the remote control with new ones of the same type. Do not mix old and new batteries or different types of batteries.**

There is risk of fire or explosion.

- **Do not recharge or disassemble the batteries. Do not dispose of batteries in a fire.**

They may burn or explode.

- **If the liquid from the batteries gets onto your skin or clothes, wash it well with clean water. Do not use the remote if the batteries have leaked.**

## 2 Information servicing

### 1. Checks to the area

Prior to beginning work on systems containing flammable refrigerants, safety checks are

necessary to ensure that the risk of ignition is minimised. For repair to the refrigerating system, the following precautions shall be complied with prior to conducting work on the system.

### 2. Work procedure

Work shall be undertaken under a controlled procedure so as to minimise the risk of a flammable gas or vapor being present while the work is being performed.

### 3. General work area

All maintenance staff and others working in the local area shall be instructed on the nature of work being carried out. Work in confined spaces shall be avoided. The area around the work space shall be sectioned off. Ensure that the conditions within the area have been made safe by control of flammable material.

### 4. Checking for presence of refrigerant

The area shall be checked with an appropriate refrigerant detector prior to and during work, to ensure the technician is aware of potentially flammable atmospheres. Ensure that the

leak detection equipment being used is suitable for use with flammable refrigerants, i.e. no sparking, adequately sealed or intrinsically safe.

#### **5. Presence of fire extinguisher**

If any hot work is to be conducted on the refrigeration equipment or any associated parts, appropriate fire extinguishing equipment shall be available to hand. Have a dry powder or CO<sub>2</sub> fire extinguisher adjacent to the charging area.

#### **6. No ignition sources**

No person carrying out work in relation to a refrigeration system which involves exposing any pipe work that contains or has contained flammable refrigerant shall use any sources of ignition in such a manner that it may lead to the risk of fire or explosion. All possible ignition sources, including cigarette smoking, should be kept sufficiently far away from the site of installation, repairing, removing and disposal, during which flammable refrigerant can possibly be released to the surrounding space. Prior to work taking place, the area around the equipment is to be surveyed to make sure that there are no flammable hazards or ignition risks. NO SMOKING signs shall be displayed.

#### **7. Ventilated area**

Ensure that the area is in the open or that it is adequately ventilated before breaking into the system or conducting any hot work. A degree of ventilation shall continue during the period

that the work is carried out. The ventilation should safely disperse any released refrigerant and preferably expel it externally into the atmosphere.

#### **8. Checks to the refrigeration equipment**

Where electrical components are being changed, they shall be fit for the purpose and to the correct specification. At all times the manufacturer's maintenance and service guidelines shall be followed. If in doubt consult the manufacturer's technical department for assistance. The following checks shall be applied to installations using flammable refrigerants:

- the charge size is in accordance with the room size within which the refrigerant containing parts are installed;
- the ventilation machinery and outlets are operating adequately and are not obstructed;
- if an indirect refrigerating circuit is being used, the secondary circuit shall be checked for the presence of refrigerant; marking to the equipment continues to be visible and legible.
- markings and signs that are illegible shall be corrected;
- refrigeration pipe or components are installed in a position where they are unlikely to be exposed to any substance which may corrode refrigerant containing components, unless the components are constructed of materials which are inherently resistant to being corroded or are suitably protected against being so corroded.

#### **9. Checks to electrical devices**

Repair and maintenance to electrical components shall include initial safety checks and component inspection

procedures. If a fault exists that could compromise safety, then no electrical supply shall be connected to the circuit until it is satisfactorily dealt with. If the fault cannot be corrected immediately but it is necessary to continue operation, an adequate temporary solution shall be used. This shall be reported to the owner of the equipment so all parties are advised. Initial safety checks shall include:

- that capacitors are discharged: this shall be done in a safe manner to avoid possibility of sparking;
- that there no live electrical components and wiring are exposed while charging, recovering or purging the system;
- that there is continuity of earth bonding.

#### **10. Repairs to sealed components**

10.1 During repairs to sealed components, all electrical supplies shall be disconnected from the equipment being worked upon prior to any removal of sealed covers, etc. If it is absolutely necessary to have an electrical supply to equipment during servicing, then a permanently operating form of leak detection shall be located at the most critical point to warn of a potentially hazardous situation.

10.2 Particular attention shall be paid to the following to ensure that by working on electrical

components, the casing is not altered in such a way that the level of protection is affected. This shall include damage to cables, excessive number of connections, terminals not made to original specification, damage to seals, incorrect fitting of glands, etc.

- Ensure that apparatus is mounted securely.
- Ensure that seals or sealing materials have not degraded such that they no

longer serve the purpose of preventing the ingress of flammable atmospheres.

Replacement parts shall be in accordance with the manufacturer's specifications.

NOTE: The use of silicon sealant may inhibit the effectiveness of some types of leak detection equipment. Intrinsically safe components do not have to be isolated prior to working on them.

#### **11. Repair to intrinsically safe components**

Do not apply any permanent inductive or capacitance loads to the circuit without ensuring that this will not exceed the permissible voltage and current permitted for the equipment in use. Intrinsically safe components are the only types that can be worked on while live in the presence of a flammable atmosphere. The test apparatus shall be at the correct rating.

Replace components only with parts specified by the manufacturer. Other parts may result in the ignition of refrigerant in the atmosphere from a leak.

#### **12. Cabling**

Check that cabling will not be subject to wear, corrosion, excessive pressure, vibration, sharp edges or any other adverse environmental effects. The check shall also take into account the effects of aging or continual vibration from sources such as compressors or fans.

#### **13. Detection of flammable refrigerants**

Under no circumstances shall potential sources of ignition be used in the searching for or detection of refrigerant leaks. A halide torch (or any other detector using a naked flame) shall not be used.

#### **14. Leak detection methods**



The following leak detection methods are deemed acceptable for systems containing flammable refrigerants. Electronic leak detectors shall be used to detect flammable refrigerants, but the sensitivity may not be adequate, or may need re-calibration. (Detection equipment shall be calibrated in a refrigerant-free area.) Ensure that the detector is not a potential source of ignition and is suitable for the refrigerant used. Leak detection equipment shall be set at a percentage of the LFL of the refrigerant and shall be calibrated to the refrigerant employed and the appropriate percentage of gas (25 % maximum) is confirmed. Leak detection fluids are suitable for use with most refrigerants but the use of detergents containing chlorine shall be avoided as the chlorine may react with the refrigerant and corrode the copper pipe-work.

If a leak is suspected, all naked flames shall be removed or extinguished.

If a leakage of refrigerant is found which requires brazing, all of the refrigerant shall be

recovered from the system, or isolated (by means of shut off valves) in a part of the system

remote from the leak. Oxygen free nitrogen (OFN) shall then be purged through the system both before and during the brazing process.

### **15. Removal and evacuation**

When breaking into the refrigerant circuit to make repairs or for any other purpose conventional procedures shall be used.

However, it is important that best practice is

followed since flammability is a consideration. The following procedure shall be adhered to:

- remove refrigerant;
- purge the circuit with inert gas;

- evacuate;
- purge again with inert gas;
- open the circuit by cutting or brazing.

The refrigerant charge shall be recovered into the correct recovery cylinders. The system

shall be flushed with OFN to render the unit safe. This process may need to be repeated several times. Compressed air or oxygen shall not be used for this task.

Flushing shall be achieved by breaking the vacuum in the system with OFN and continuing to fill until the working pressure is achieved, then venting to atmosphere, and finally pulling down to a vacuum. This process shall be repeated until no refrigerant is within the system. When the final OFN charge is used, the system shall be vented down to atmospheric pressure to enable work to take place. This operation is absolutely vital if brazing operations on the pipe-work are to take place.

Ensure that the outlet for the vacuum pump is not close to any ignition sources and there is

ventilation available.

### **16. Charging procedures**

In addition to conventional charging procedures, the following requirements shall be followed:

- Ensure that contamination of different refrigerants does not occur when using charging equipment. Hoses or lines shall be as short as possible to minimize the amount of refrigerant contained in them.
- Cylinders shall be kept upright.
- Ensure that the refrigeration system is earthed prior to charging the system with refrigerant.
- Label the system when charging is complete (if not already).
- Extreme care shall be taken not to overfill the refrigeration system.

- Prior to recharging the system it shall be pressure tested with OFN. The system shall be leak tested on completion of charging but prior to commissioning. A follow up leak test shall be carried out prior to leaving the site.

### **17. Decommissioning**

Before carrying out this procedure, it is essential that the technician is completely familiar with the equipment and all its detail. It is recommended good practice that all refrigerants are recovered safely. Prior to the task being carried out, an oil and refrigerant sample shall be taken. In case analysis is required prior to re-use of reclaimed refrigerant. It is essential that electrical power is available before the task is commenced.

- Become familiar with the equipment and its operation.
- Isolate system electrically.
- Before attempting the procedure ensure that:
  - mechanical handling equipment is available, if required, for handling refrigerant cylinders;
  - all personal protective equipment is available and being used correctly;
  - the recovery process is supervised at all times by a competent person;
  - recovery equipment and cylinders conform to the appropriate standards.
- Pump down refrigerant system, if possible.
- If a vacuum is not possible, make a manifold so that refrigerant can be removed from various parts of the system.
- Make sure that cylinder is situated on the scales before recovery takes place.
- Start the recovery machine and operate in accordance with manufacturer's instructions.

h) Do not overfill cylinders. (No more than 80 % volume liquid charge).

i) Do not exceed the maximum working pressure of the cylinder, even temporarily.

j) When the cylinders have been filled correctly and the process completed, make sure that the cylinders and the equipment are removed from site promptly and all isolation valves on the equipment are closed off.

k) Recovered refrigerant shall not be charged into another refrigeration system unless it has been cleaned and checked.

### **18. Labelling**

Equipment shall be labelled stating that it has been de-commissioned and emptied of refrigerant. The label shall be dated and signed. Ensure that there are labels on the equipment stating the equipment contains flammable refrigerant.

### **19. Recovery**

- When removing refrigerant from a system, either for servicing or decommissioning, it is recommended good practice that all refrigerants are removed safely.
- When transferring refrigerant into cylinders, ensure that only appropriate refrigerant recovery cylinders are employed. Ensure that the correct numbers of cylinders for holding the total system charge are available. All cylinders to be used are designated for the recovered refrigerant and labelled for that refrigerant (i.e. special cylinders for the recovery of refrigerant). Cylinders shall be complete with pressure relief valve and associated shut-off valves in good working order.
- Empty recovery cylinders are evacuated and, if possible, cooled before recovery occurs.

- The recovery equipment shall be in good working order with a set of instructions concerning the equipment that is at hand and shall be suitable for the recovery of flammable refrigerants. In addition, a set of calibrated weighing scales shall be available and in good working order.
- Hoses shall be complete with leak-free disconnect couplings and in good condition. Before using the recovery machine, check that it is in satisfactory working order, has been properly maintained and that any associated electrical components are sealed to prevent ignition in the event of a refrigerant release. Consult manufacturer if in doubt.
- The recovered refrigerant shall be returned to the refrigerant supplier in the correct recovery cylinder, and the relevant Waste Transfer Note arranged. Do not mix refrigerants in recovery units and especially not in cylinders.
- If compressors or compressor oils are to be removed, ensure that they have been evacuated to an acceptable level to make certain that flammable refrigerant does not remain within the lubricant. The evacuation process shall be carried out prior to returning the compressor to the suppliers. Only electric heating to the compressor body shall be employed to accelerate this process. When oil is drained from a system, it shall be carried out safely.

### 3. Model list

#### Model Names of Indoor/Outdoor Units

	<b>Capacity</b>	<b>Indoor units</b>	<b>Outdoor units</b>
3D inverter	9k	P9MVI32-09WiFi	P9MVO32-09
	12k	P9MVI32-12WiFi	P9MVO32-12
	18k	P9MVI32-18WiFi	P9MVO32-18
	24k	P9MVI32-24WiFi	P9MVO32-24

## 4. Dimension

### 4.1 Indoor Unit

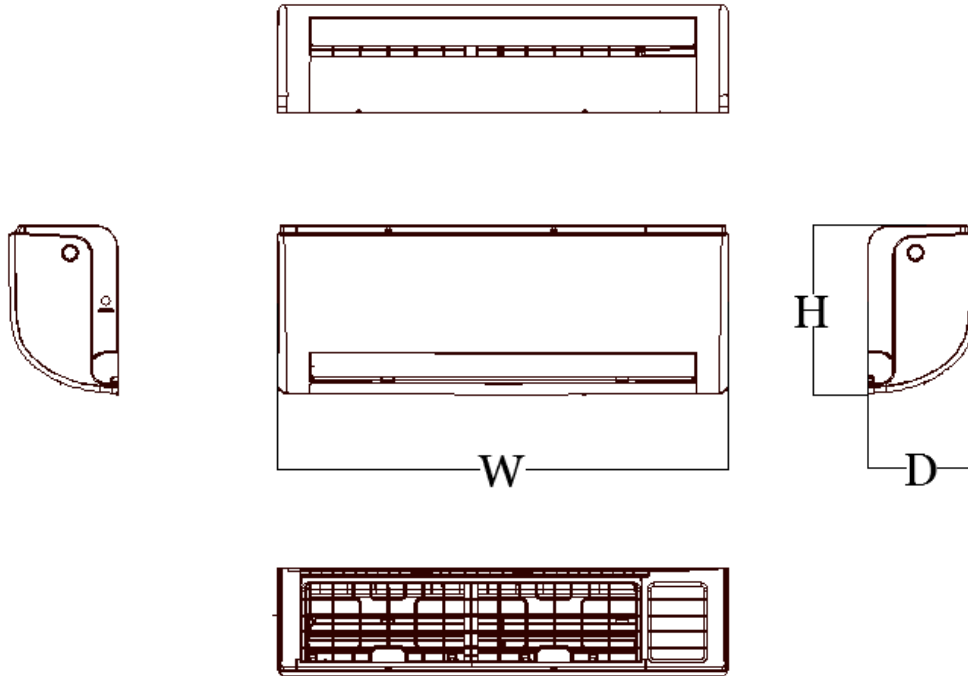

Model	W	D	H
P9MVI32-09WiFi	717	193	302
P9MVI32-12WiFi	805	193	302
P9MVI32-18WiFi	964	222	325
P9MVI32-24WiFi	1106	232	342

For P9MVI32-09WiFi,

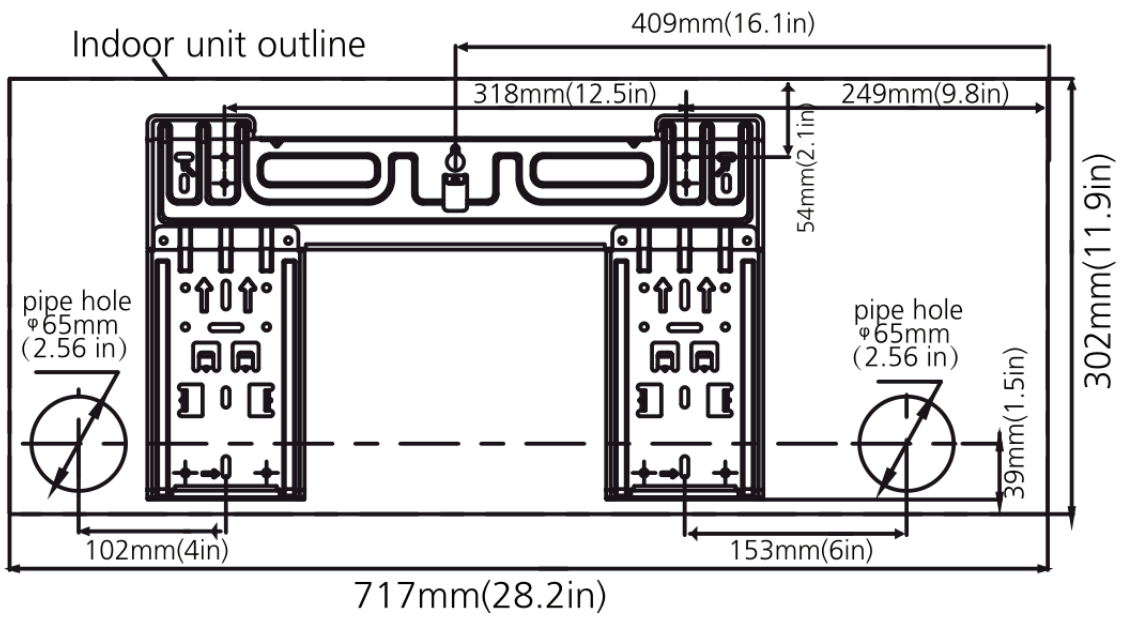

Model A

For P9MVI32-09WiFi / P9MVO32-09, P9MVI32-12WiFi / P9MVO32-12

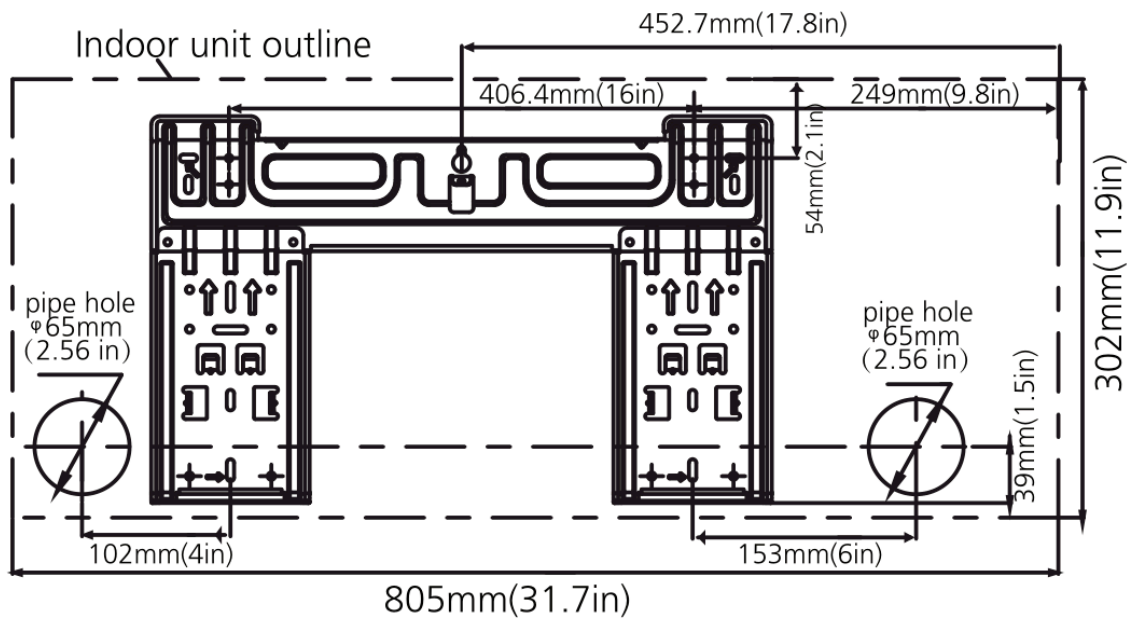

Model B

For P9MVI32-18WiFi / P9MVO32-18,

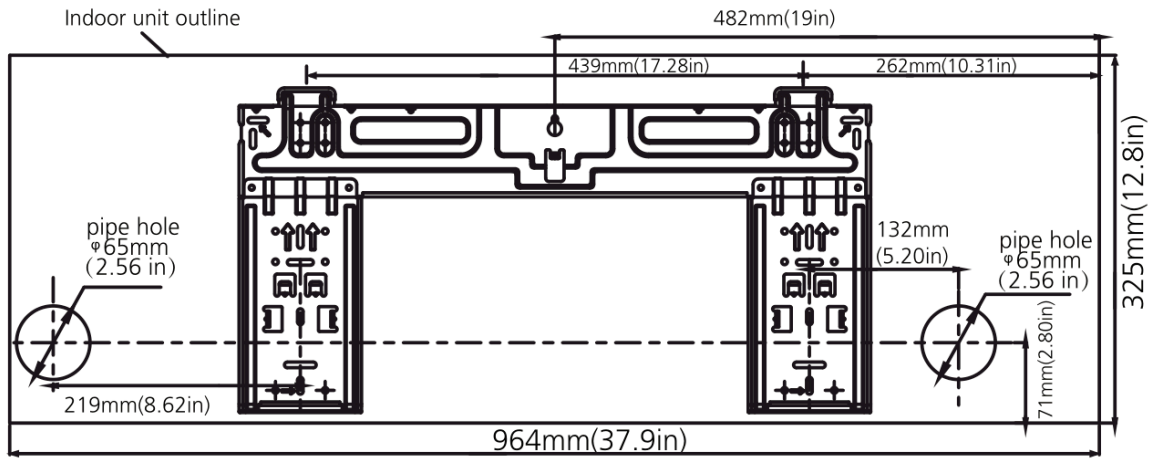

Model C

For P9MVI32-24WiFi / P9MVO32-24,

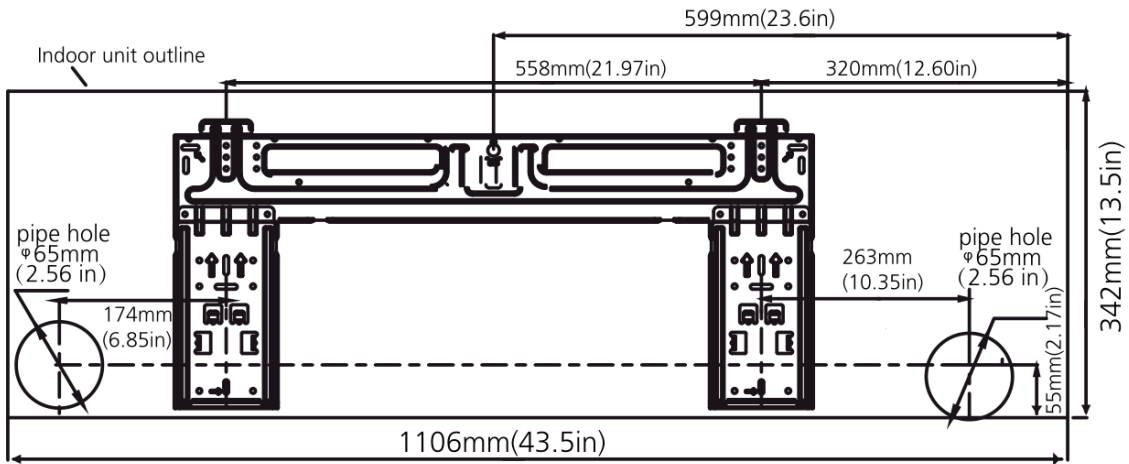

Model D

## 4.2 Outdoor Unit

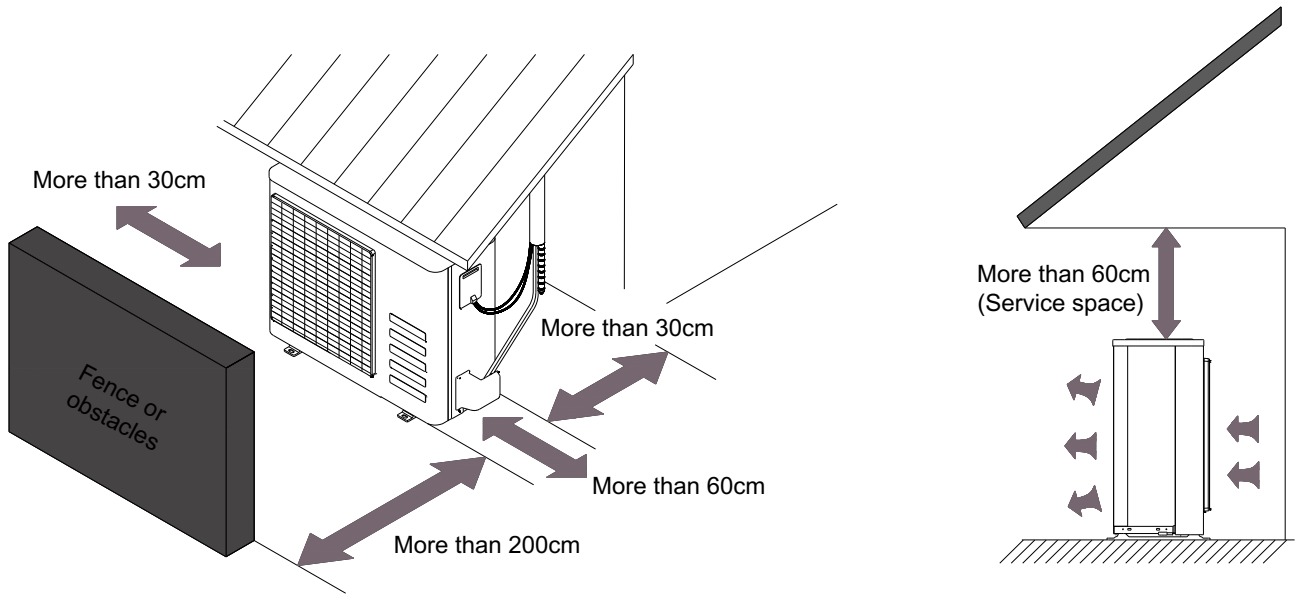



For P9MVO32-09, P9MVO32-12,

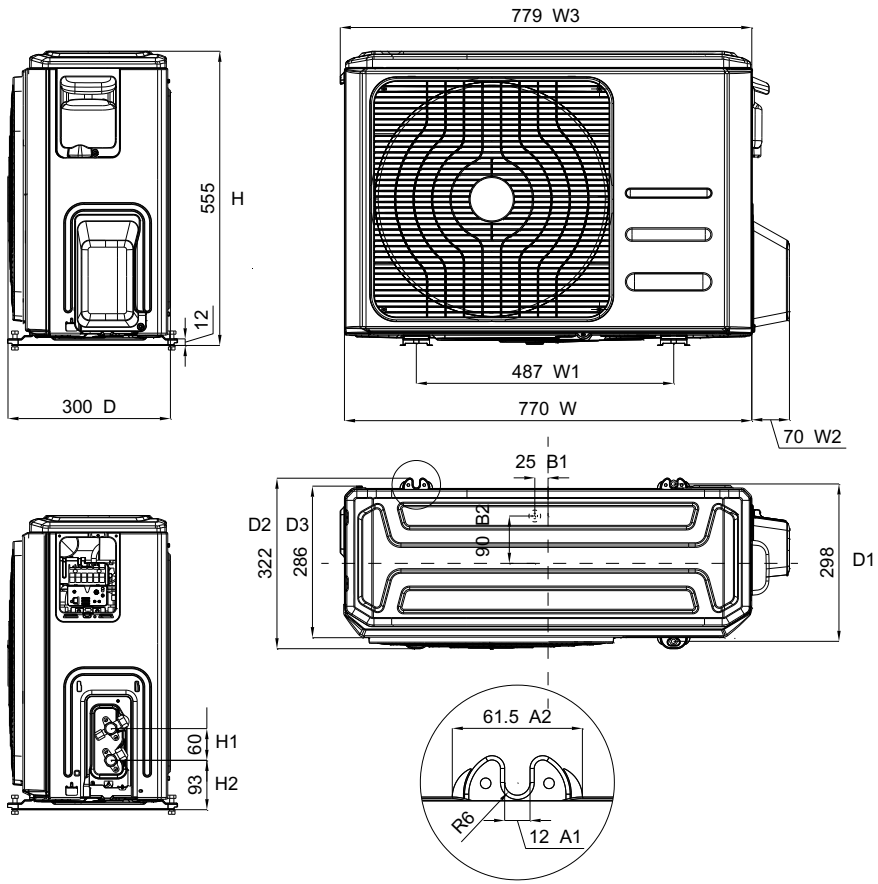

For P9MVO32-09, P9MVO32-12, P9MVO32-18

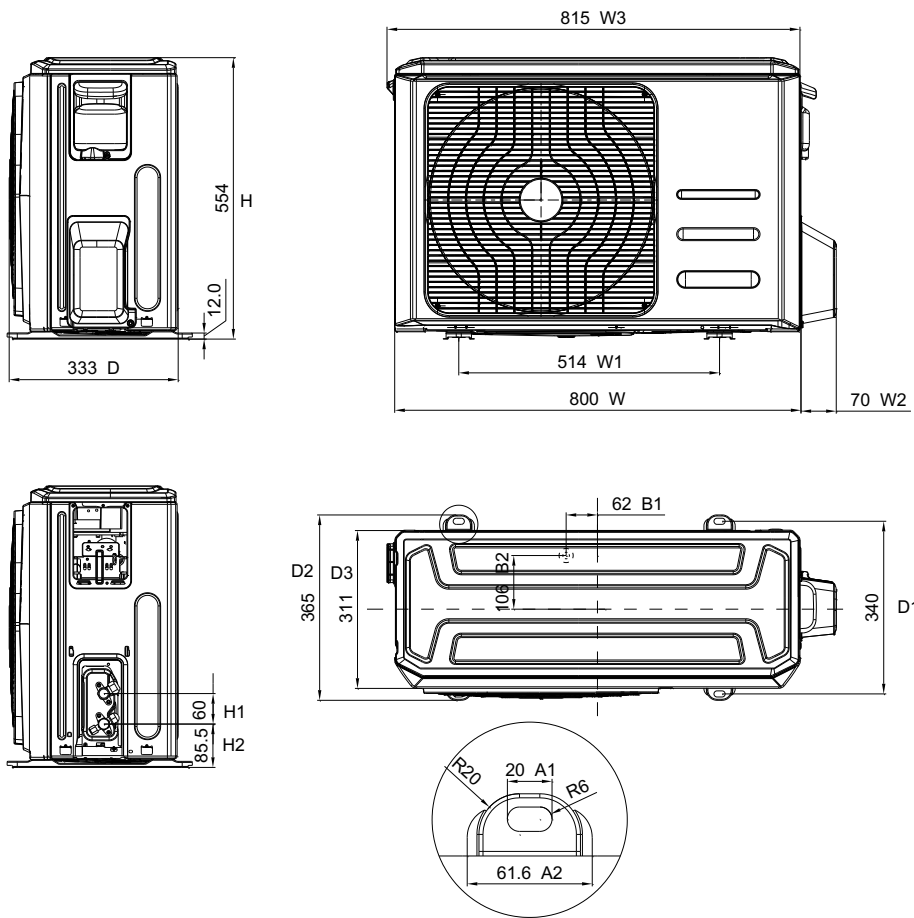

For P9MVO32-24,

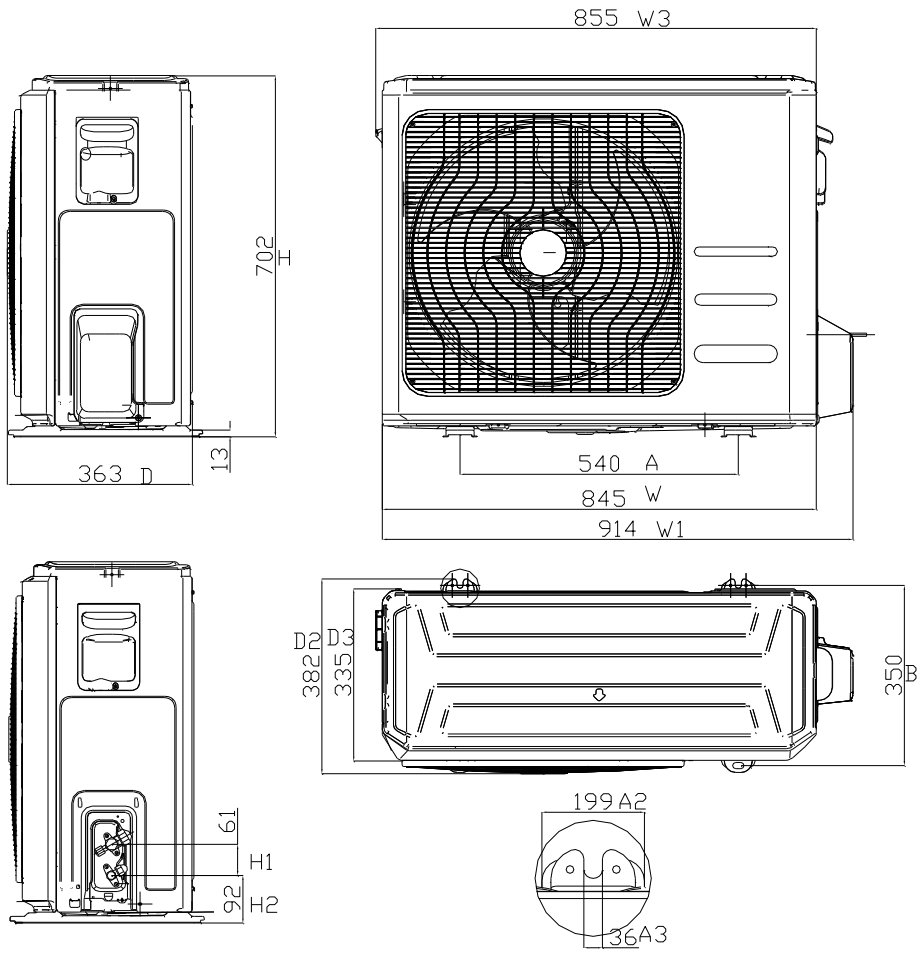

# 5. Refrigerant Cycle Diagram

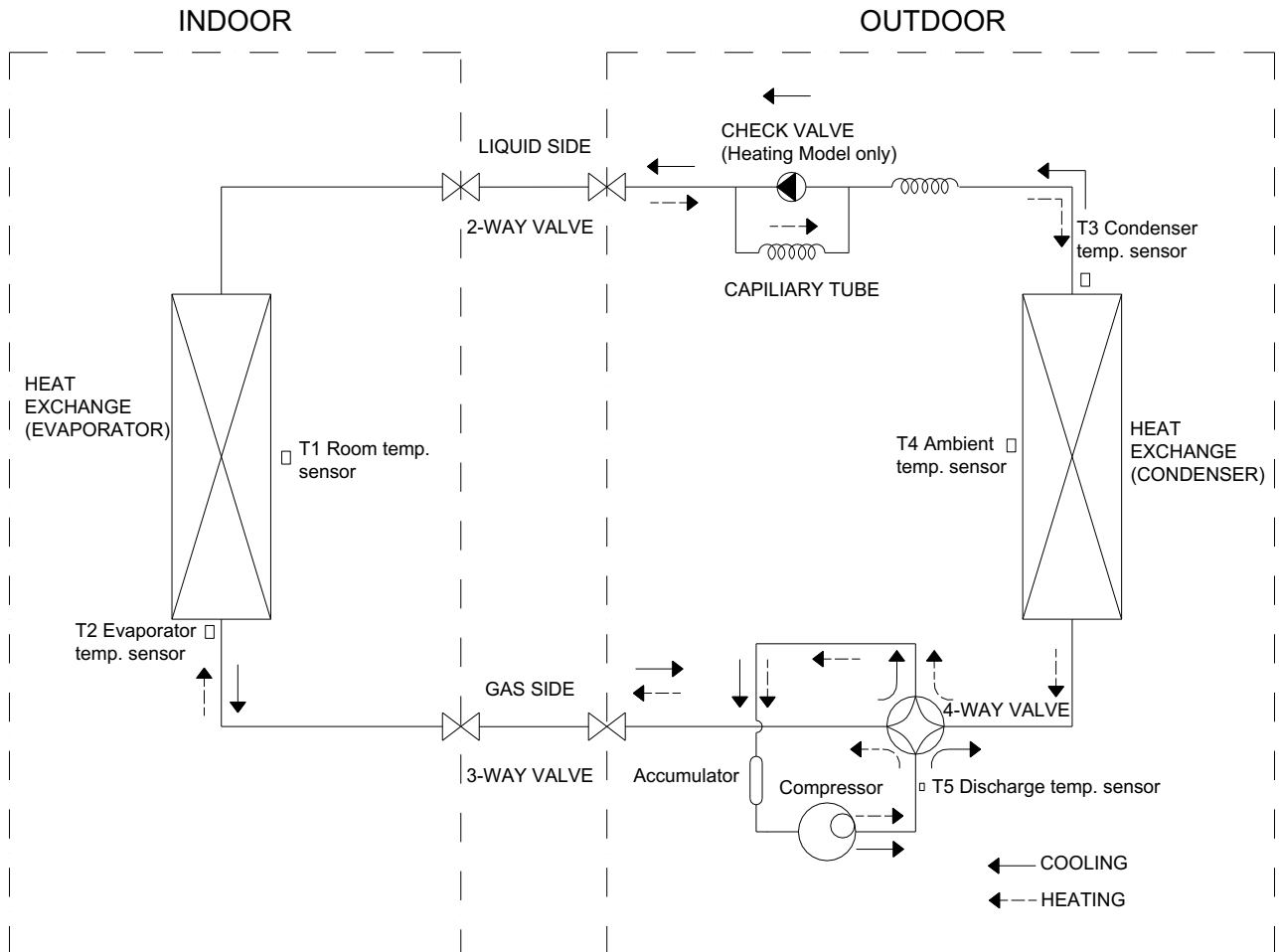

## 6 Installation Details

### 6.1 Wrench torque sheet for installation

Outside diameter		Torque	Additional tightening torque
mm	inch	N.cm	N.cm
Φ6.35	1/4	1500(153kgf.cm)	1600(163kgf.cm)
Φ9.52	3/8	2500(255kgf.cm)	2600(265kgf.cm)
Φ12.7	1/2	3500(357kgf.cm)	3600(367kgf.cm)
Φ15.9	5/8	4500(459kgf.cm)	4700(479kgf.cm)
Φ19	3/4	6500(663kgf.cm)	6700(683kgf.cm)

### 6.2 Connecting the cables

The power cord of connect should be selected according to the following specifications sheet.

Rated current of appliance	Nominal cross-sectional area (mm <sup>2</sup> )
>3 and ≤6	0.75
>6 and ≤10	1
>10 and ≤16	1.5
>16 and ≤25	2.5

The cable size and the current of the fuse or switch are determined by the maximum current indicated on the nameplate which located on the side panel of the unit. Please refer to the nameplate before selecting the cable, fuse and switch.

### 6.3 Pipe length and the elevation

#### The pipe length and refrigerant amount:

Model	Pipe size		Standard length (m)	Max. Elevation B (m)	Max. Length A (m)	Additional refrigerant (g/m)
	Gas	Liquid				
P9MVI32-09WiFi / P9MVO32-09	3/8" (Φ9.52)	1/4" (Φ6.35)	5	10	25	12
P9MVI32-12WiFi / P9MVO32-12	3/8" (Φ9.52)	1/4" (Φ6.35)	5	10	25	12
P9MVI32-18WiFi / P9MVO32-18	1/2" (Φ12.7)	1/4" (Φ6.35)	5	20	30	12
P9MVI32-24WiFi / P9MVO32-24	5/8" (Φ15.9)	3/8" (Φ9.52)	5	25	50	24

#### Caution:

For the R290 or R32 refrigerant model, make sure the conditions within the area have been made safe by control of flammable material when the refrigerant added into air conditioner. The maximum refrigerant charge amount of R290 is 305 grams.

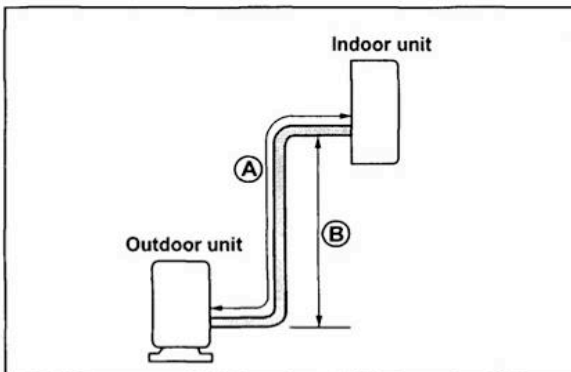

#### Caution:

The capacity test is based on the standard length and the maximum permissible length is based on the system reliability.

## 6.4 Installation for the first time

Air and moisture in the refrigerant system have undesirable effects as below:

- Pressure in the system rises.
- Operating current rises.
- Cooling or heating efficiency drops.
- Moisture in the refrigerant circuit may freeze and block capillary tubing.
- Water may lead to corrosion of parts in the refrigerant system.

Therefore, the indoor units and the pipes between indoor and outdoor units must be leak tested and evacuated to remove gas and moisture from the system.

Gas leak check (Soap water method):

Apply soap water or a liquid neutral detergent on the indoor unit connections or outdoor unit connections by a soft brush to check for leakage of the connecting points of the piping. If bubbles come out, the pipes have leakage.

### 1. Air purging with vacuum pump

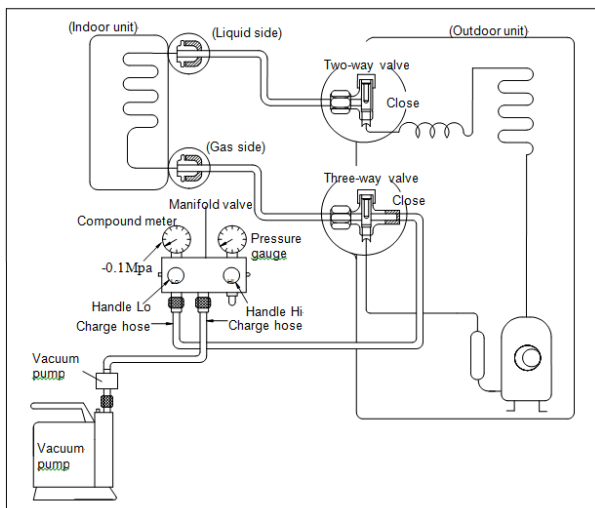

- 1) Completely tighten the flare nuts of the indoor and outdoor units, confirm that both the 2-way and 3-way valves are set to the closed position.
- 2) Connect the charge hose with the push pin of handle lo to the 3-way valves gas service port..

- 3) Connect the charge hose of handle hi connection to the vacuum pump.
- 4) Fully open the handle Lo of the manifold valve.
- 5) Operate the vacuum pump to evacuate.
- 6) Make evacuation for 30 minutes and check whether the compound meter indicates -0.1Mpa. If the meter does not indicate -0.1Mpa after pumping 30 minutes, it should be pumped 20 minutes more. If the pressure can't achieve -0.1Mpa after pumping 50 minutes, please check if there are some leakage points.

Fully close the handle Lo valve of the manifold valve and stop the operation of the vacuum pump. Confirm that the gauge needle does not move (approximately 5 minutes after turning off the vacuum pump).

- 7) Turn the flare nut of the 3-way valves about 45° counterclockwise for 6 or 7seconds after the gas coming out, then tighten the flare nut again. Make sure the pressure display in the pressure indicator is a little higher than the atmosphere pressure. Then remove the charge hose from the 3 way valve.
- 8) Fully open the 2 way valve and 3 way valve and securely tighten the cap of the 3 way valve.

### 2. Adding the refrigerant if the pipe length >5m

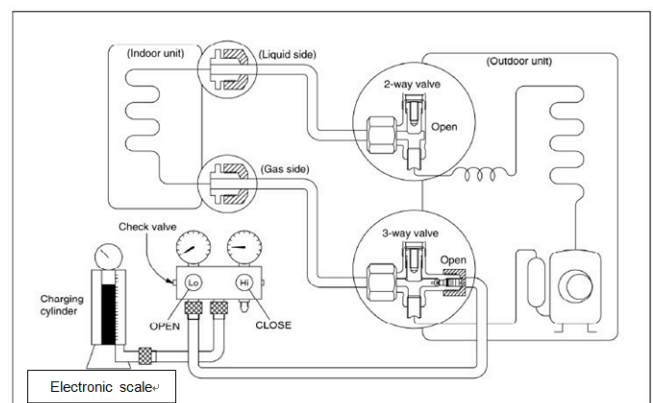

### Procedure:

1). Connect the charge hose to the charging cylinder, open the 2-way valve and the 3-way valve.

Connect the charge hose which you disconnected from the vacuum pump to the valve at the bottom of the cylinder. Make the cylinder bottom up to ensure the liquid charge.

2). Purge the air from the charge hose. Open the valve at the bottom of the cylinder and press the check valve on the charge set to purge the air (be careful of the liquid refrigerant).

3) Put the charging cylinder onto the electronic scale and record the weight.

4) Operate the air conditioner at the cooling mode.

5) Open the valves (Low side) on the charge set and charge the system with liquid refrigerant.

6).When the electronic scale displays the proper weight (refer to the table), disconnect the charge hose from the 3-way valve's service port immediately and turn off the air conditioner before disconnecting the hose.

7). Mount the valve stem caps and the service port

Use torque wrench to tighten the service port cap to a torque of 18N.m.

Be sure to check for gas leakage.

### 6.5 Adding the refrigerant after running the system for many years

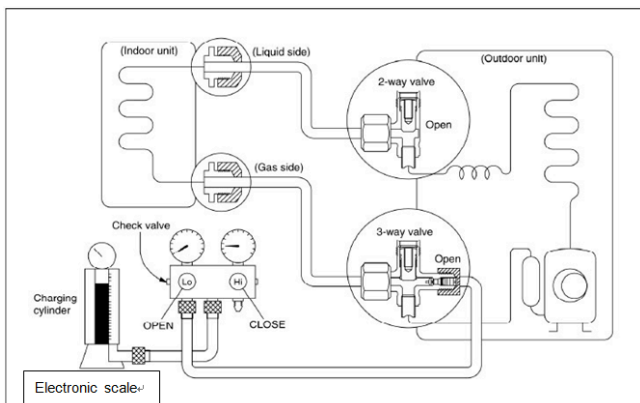

### Procedure:

1). Connect the charge hose to the 3-way service port, open the 2-way valve and the 3-way valve.

Connect the charge hose to the valve at the bottom of the cylinder. Make the cylinder bottom up to ensure liquid charge.

2). Purge the air from the charge hose. Open the valve at the bottom of the cylinder and press the check valve on the charge set to purge the air (be careful of the liquid refrigerant).

3) Put the charging cylinder onto the electronic scale and record the weight.

4) Operate the air conditioner at the cooling mode.

5) Open the valves (Low side) on the charge set and charge the system with liquid refrigerant.

6).When the electronic scale displays the proper weight (refer to the gauge and the pressure of the low side), disconnect the charge hose from the 3-way valve's service port immediately and turn off the air conditioner before disconnecting the hose.

7). Mount the valve stem caps and the service port

Use torque wrench to tighten the service port cap to a torque of 18N.m.

Be sure to check for gas leakage.

### 6.6 Re-installation while the indoor unit need to be repaired

#### 1. Collecting the refrigerant into the outdoor unit



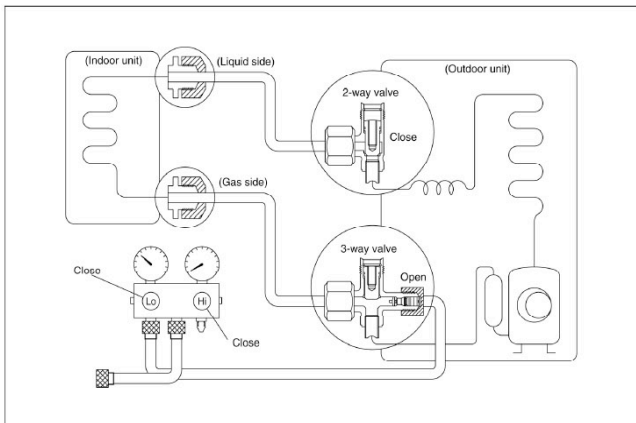

## Procedure

1). Confirm that both the 2-way and 3-way valves are set to the opened position

Remove the valve stem caps and confirm that the valve stems are in the opened position.

Be sure to use a hexagonal wrench to operate the valve stems.

2). Connect the charge hose with the push pin of handle lo to the 3-way valves gas service port.

3). Air purging of the charge hose.

Open the handle Lo valve of the manifold valve slightly to purge air from the charge hose for 5 seconds and then close it quickly.

4). Set the 2-way valve to the close position.

5). Operate the air conditioner at the cooling cycle and stop it when the gauge indicates 0.1MPa.

6). Set the 3-way valve to the closed position immediately

Do this quickly so that the gauge ends up indicating 0.3 to 0.5Mpa.

Disconnect the charge set, and tighten the 2-way and 3-way valve's stem nuts.

Use a torque wrench to tighten the 3-way valves service port cap to a torque of 18N.m.

Be sure to check for gas leakage.

## 2. Air purging with vacuum pump

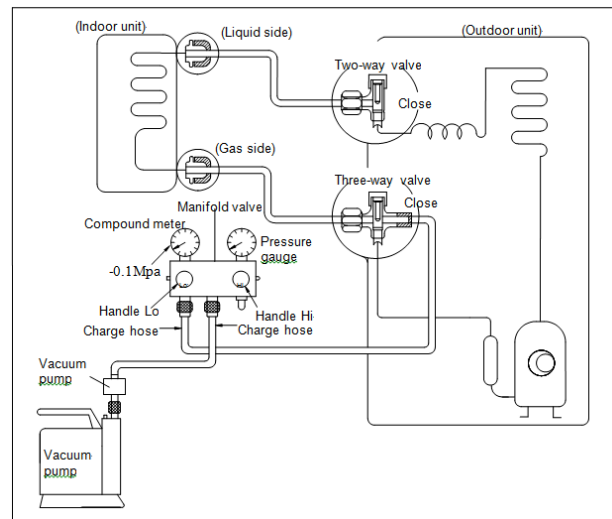

- 1) Completely tighten the flare nuts of the indoor and outdoor units, confirm that both the 2-way and 3-way valves are set to the closed position.
- 2) Connect the charge hose with the push pin of handle lo to the 3-way valves gas service port.
- 3) Connect the charge hose of handle hi connection to the vacuum pump.
- 4) Fully open the handle Lo of the manifold valve.
- 5) Operate the vacuum pump to evacuate.
- 6) Make evacuation for 30 minutes and check whether the compound meter indicates -0.1Mpa. If the meter does not indicate -0.1Mpa after pumping 30 minutes, it should be pumped 20 minutes more. If the pressure can't achieve -0.1Mpa after pumping 50 minutes, please check if there are some leakage points.  
Fully close the handle Lo valve of the manifold valve and stop the operation of the vacuum pump. Confirm that the gauge needle does not move (approximately 5 minutes after turning off the vacuum pump).
- 7) Turn the flare nut of the 3-way valves about 45° counterclockwise for 6 or 7seconds after the gas

coming out, then tighten the flare nut again. Make sure the pressure display in the pressure indicator is a little higher than the atmosphere pressure. Then remove the charge hose from the 3 way valve.

8) Fully open the 2 way valve and 3 way valve and securely tighten the cap of the 3 way valve.

## 6.7 Re-installation while the outdoor unit need to be repaired

### 1. Evacuation for the whole system

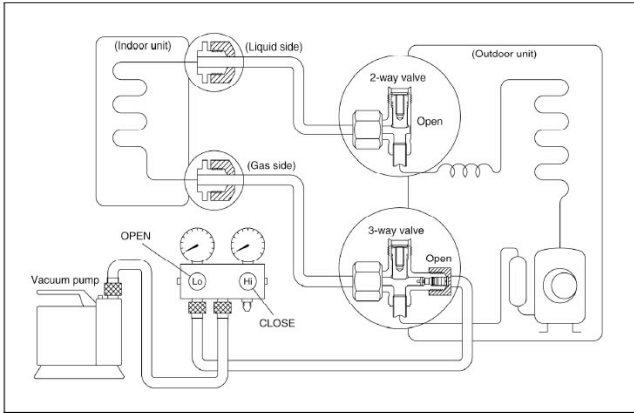

#### Procedure:

- 1). Confirm that both the 2-way and 3-way valves are set to the opened position.
- 2). Connect the vacuum pump to 3-way valve's service port.
- 3). Evacuation for approximately one hour. Confirm that the compound meter indicates  $-0.1\text{Mpa}$ .
- 4). Close the valve (Low side) on the charge set, turn off the vacuum pump, and confirm that the gauge needle does not move (approximately 5 minutes after turning off the vacuum pump).
- 5). Disconnect the charge hose from the vacuum pump.

### 2. Refrigerant charging

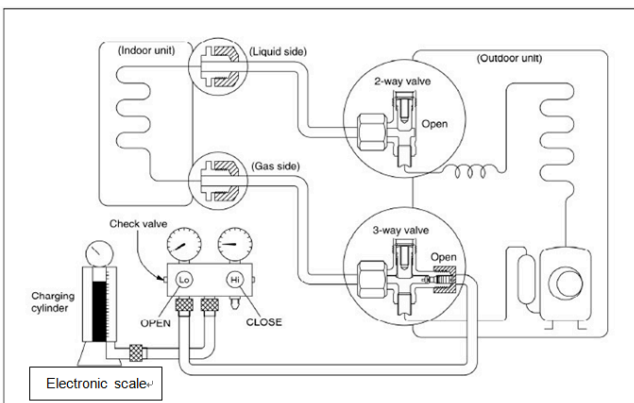

#### Procedure:

- 1). Connect the charge hose to the charging cylinder, open the 2-way valve and the 3-way valve

Connect the charge hose which you disconnected from the vacuum pump to the valve at the bottom of the cylinder. Make the cylinder bottom up to ensure liquid charge.

- 2). Purge the air from the charge hose  
Open the valve at the bottom of the cylinder and press the check valve on the charge set to purge the air (be careful of the liquid refrigerant).
- 3) Put the charging cylinder onto the electronic scale and record the weight.
- 4). Open the valves (Low side) on the charge set and charge the system with liquid refrigerant

If the system cannot be charge with the specified amount of refrigerant, or can be charged with a little at a time (approximately 150g each time) , operating the air conditioner in the cooling cycle; however, one time is not sufficient, wait approximately 1 minute and then repeat the procedure.

- 5). When the electronic scale displays the proper weight, disconnect the charge hose from the 3-way valve's service port immediately

If the system has been charged with liquid refrigerant while operating the air conditioner, turn off the air conditioner before disconnecting the hose.

- 6). Mounted the valve stem caps and the service port

Use torque wrench to tighten the service port cap to a torque of  $18\text{N.m}$ .

Be sure to check for gas leakage.

## 7. Disassemble Guide

### 7.1 How to Remove the filter

Step1:

Put your hands at A and B, lift the filter a little to loosen the fastener



Step2:

Pull the filter gently along the horizontal direction.

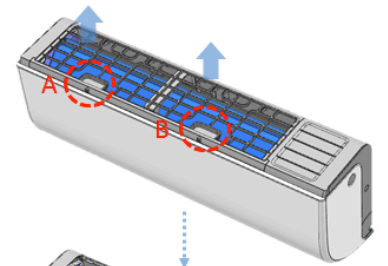

Step3:

Pull out the filter.

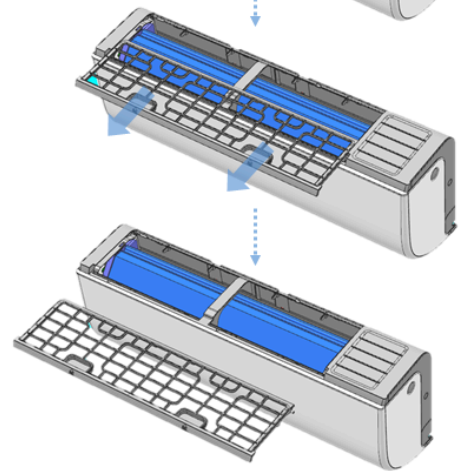

### 7.2 How to Remove the horizontal louver

Step1:

Open the horizontal louver ,push the locker towards right to open it.

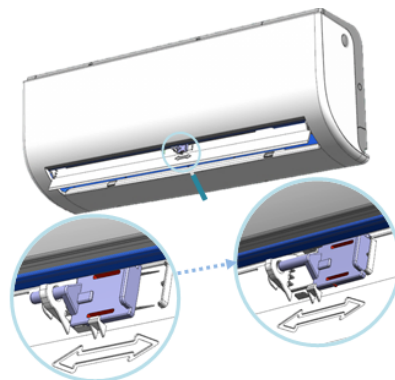

Step2:

Bend the horizontal louver lightly, remove it from the indoor unit.

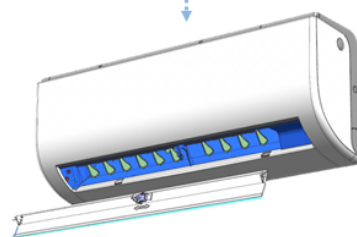

### 7.3 How to hold the indoor for piping connection

Step1:

Open the screw caps A and B, remove the two screws.

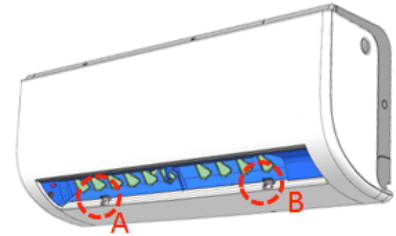

Step2:

Open the panel assembly, move the slider to fix the panel.

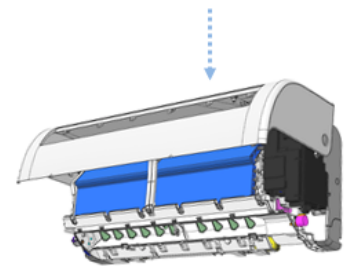

Step3:

Press the locker A and B, to lose the indoor from the installation plate

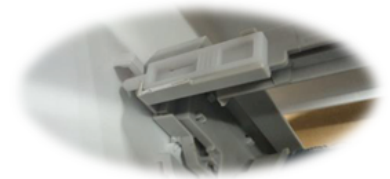

Step4:

Unfold the supporter of Installation plate, then let it to hold the indoor unit, helpful to do pipe connection in the back

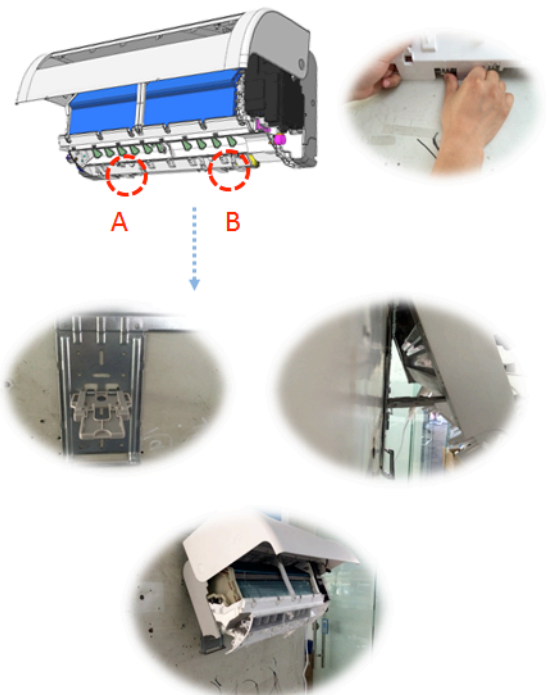

## 7.4 How to Remove the panel assembly

### Step1:

Open the screw caps A and B, remove the two screws.

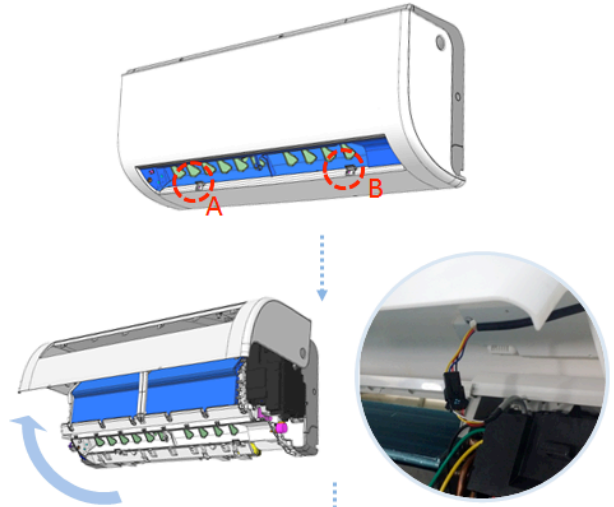

### Step2:

Open the panel assembly, loosen the display board connector.

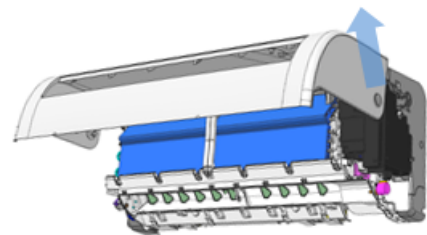

### Step3:

Pull the panel assembly along the direction indicated in right image to remove it.

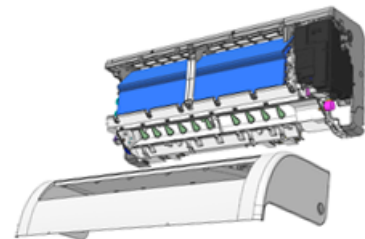

## 7.5 How to Remove the PCB

Step1:

Press A to remove the terminal cover.

Step2:

Remove screw B to remove the cover of the electronic control box .

Step3:

Then you can remove the PCB.

Note:

It is not necessary to remove the panel to remove the PCB. in order to show clearly inside, these pictures are without panel.

to show clearly inside, these pictures are without panel.

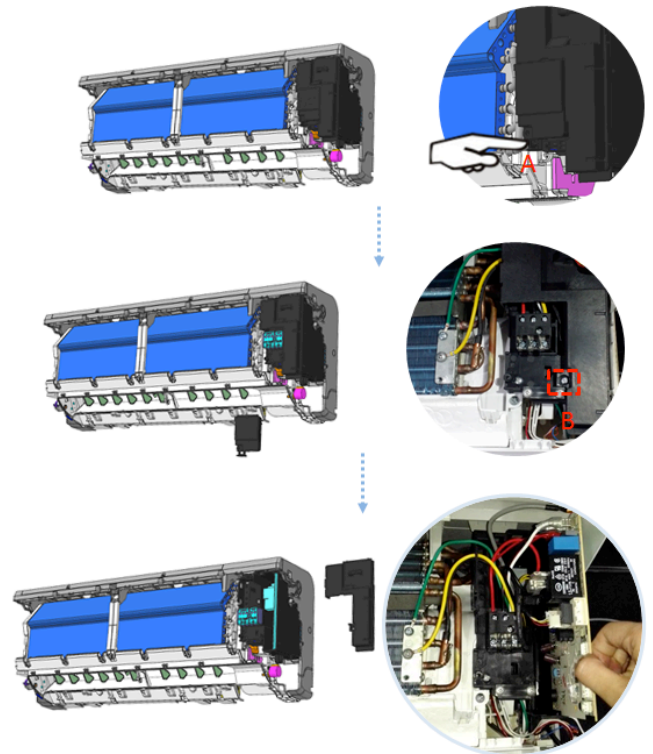

## 7.6 How to Remove the Electrical control box

Step1:

Remove screw A,B,C, pull out the coil temperature sensor D from the sensor holders.

Step2:

pull out the Electrical control box.

Note:

It is not necessary to remove the panel to remove the Electrical control box, in order

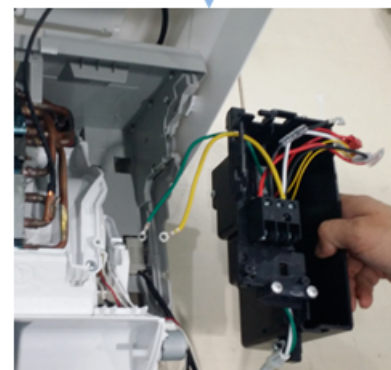
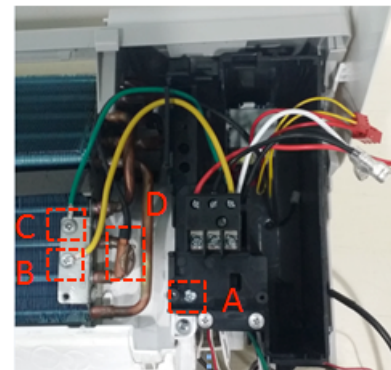

## 7.7 How to Remove the Chassis assembly

**CAUTION:** Because the 24K indoor unit is relatively large and heavy, it must have two persons to implement the following steps.

Step1:  
Remove the left and right pipe cover.

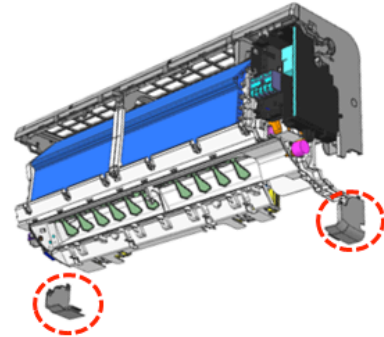

Step2:  
Remove the 5 screws A,B,C,D,E remove support part F and G.

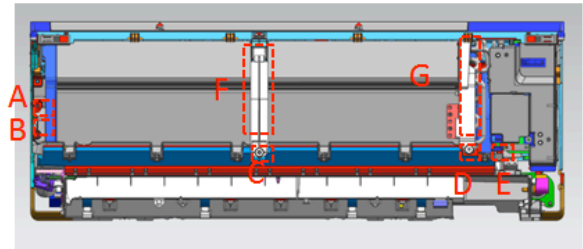

Step3:  
Open the E-box, to lose the fan motor and louver motor connectors from the PCB.

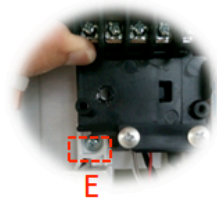

Step4:  
Press the locker H and I, to lose the indoor from the installation plate, lift it a little and pull out it along the direction indicated in right image.

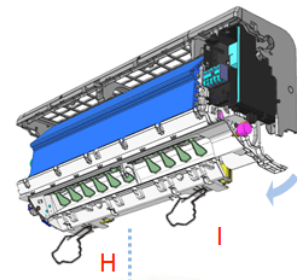
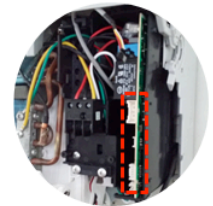
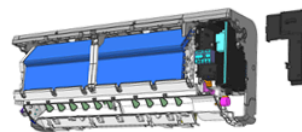

Note:  
It is not necessary to remove the panel to remove the Chassis assembly, in order to show clearly inside, these pictures are without panel

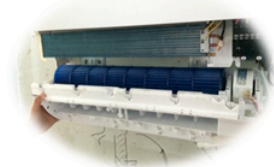



## 7.8 How to Remove the Evaporator assembly

**CAUTION:** Because the 24K indoor unit is relatively large and heavy, it must have two persons to implement the following steps.

Step1:  
Remove the Electric control box.



Step2:  
Remove the Chassis assembly



Step3:  
Unfold the Pipe clamp board C, remove screw A and B.

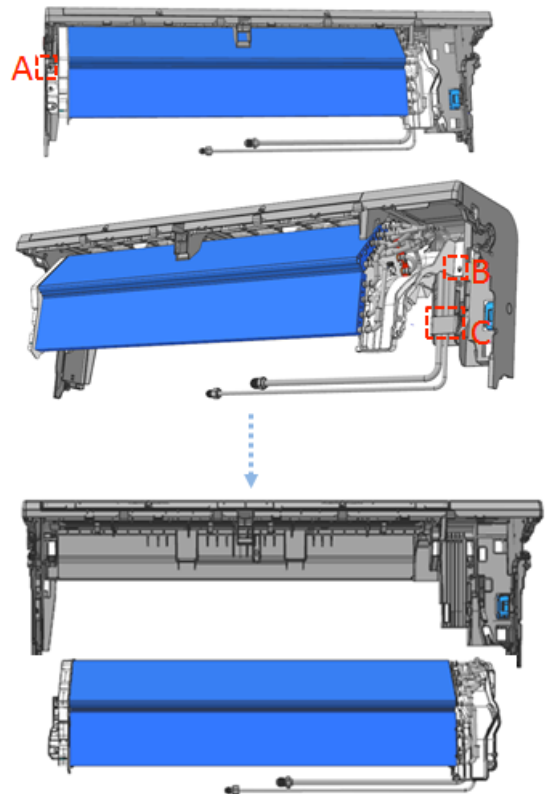

Step4:  
Pull out the evaporator.

# 8. Wiring Diagram

## 8.1 Indoor Unit

P9MVI32-09WiFi, P9MVI32-12WiFi, P9MVI32-18WiFi, P9MVI32-24WiFi

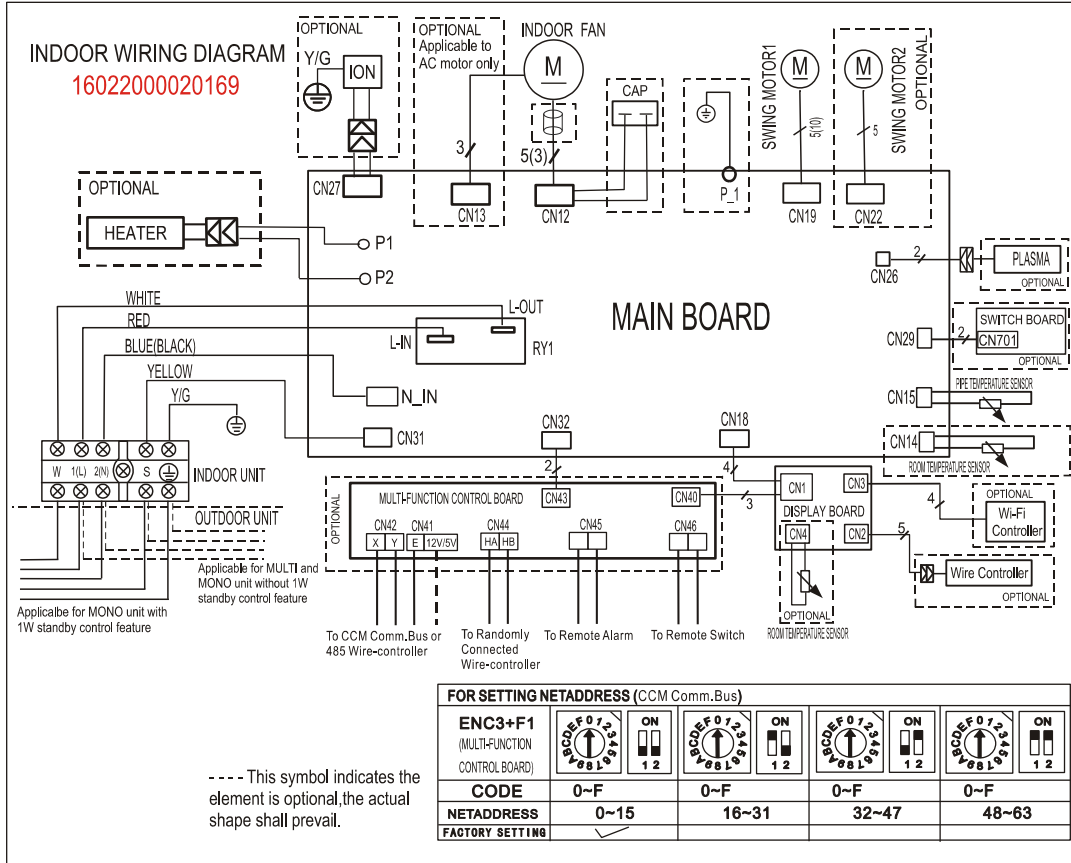

## 8.2 Outdoor Unit

P9MVO32-09, P9MVO32-12, P9MVO32-18, P9MVO32-24

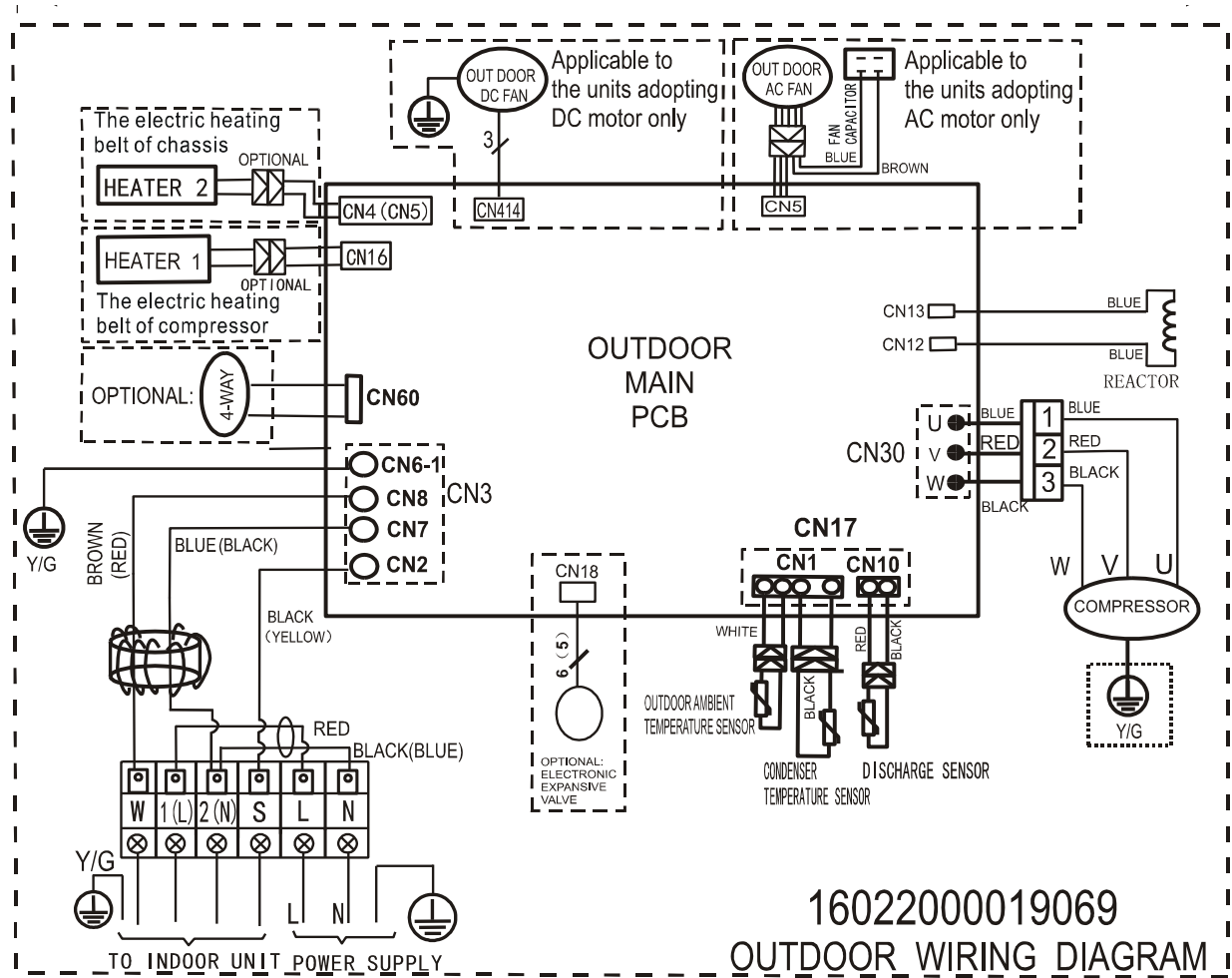

16022000019069  
OUTDOOR WIRING DIAGRAM

## 9. Operation Characteristics

Mo de Temperature	Cooling operation	Heating operation	Drying operation
Room temperature	17°C~32°C (62°F~90°F)	0°C~30°C (32°F~86°F)	10°C~32°C (50°F~90°F)
Outdoor temperature	0°C~50°C (32°F~122°F)	-15°C~30°C (5°F~86°F)	0°C~50°C (32°F~122°F)
	-15°C~50°C (5°F~122°F) (For the models with low temperature cooling system)		

### CAUTION:

1. If the air conditioner is used beyond the above conditions, certain safety protection features may come into operation and cause the unit to operate abnormally.
2. The room relative humidity should be less than 80%. If the air conditioner operates beyond this figure, the surface of the air conditioner may attract condensation. Please set the vertical air flow louver to its maximum angle (vertically to the floor), and set HIGH fan mode.
3. The optimum performance will be achieved during this operating temperature zone.

## 10. Electronic function

### 10.1 Abbreviation

- T1: Indoor room temperature
- T2: Coil temperature of evaporator
- T3: Coil temperature of condenser
- T4: Outdoor ambient temperature
- TP: Compressor discharge temperature

### 10.2 Display function

10.2.1 Icon explanation on indoor display board.



Digital display:

Displays the temperature settings when the air conditioner is operational.

Displays the room temperature in Fan and Drying mode.

Displays the self-diagnostic codes.

Displays 'ON' for three seconds when Timer ON, Fresh, Swing, Turbo or Silence feature is activated.

Displays 'OF' for three seconds when Timer OFF is set.

Displays 'OF' for three seconds when Fresh, Swing, Turbo or Silence feature is cancelled.

Displays 'dF' under defrosting operation.

Displays 'cF' when anti-cold air feature is activated under heating mode.

Displays 'SC' during self clean operation (if applicable).

Displays 'FP' when freeze protection is turned on (if applicable).

When ECO function(optional) is activated, the "88" illuminates gradually one by one as

**E → C → D → set temperature → E ...**

In one second interval.



WIFI control display(optional)

Displays when the WIFI control feature is activated. (Not available when the unit does not have this function)

NOTE:

A guide on using the infrared remote is not included in this literature package

## **10.3 Main Protection**

### **10.3.1 Three minutes delay at restart for compressor**

Less than 1 minute delay for the 1<sup>st</sup> time start-up and 3 minutes delay for others.

### **10.3.2 Temperature protection of compressor discharge**

Compressor discharge temperature  $T5 > 108^{\circ}\text{C}$  for 9s, compressor stops.

### **10.3.3 Fan speed is out of control**

When indoor fan speed keeps too low (300RPM) for certain time, the unit will stop and the LED will display the failure

### **10.3.4 Inverter module protection**

The Inverter module has a protection function about current, voltage and temperature. If these protections happen, the corresponding code will display on indoor unit and the unit will stop working.

### **10.3.5 Indoor fan delayed open function**

When the unit starts up, the louver will be active immediately and the indoor fan will open 7s later.

If the unit runs in heating mode, the indoor fan will be also controlled by anti-cold wind function.

### **10.3.6 Compressor preheating functions**

Preheating permitting condition:

When  $T4$ (outdoor ambient temperature)  $< 3^{\circ}\text{C}$ , the preheating function will be activated.

### **10.3.7 Sensor protection at open circuit and breaking disconnection.**

When there's only one temperature sensor in malfunction, the air conditioner will keep working but show the error code, in case of any emergency use.

When there's more than one temperature sensor in malfunction, the air conditioner will stop working

### **10.3.8 Refrigerant leakage detection**

This function is only active in cooling mode. It can better prevent the compressor being damaged by refrigerant leakage or compressor overload.

Open condition:

When compressor is active, the value of the Coil temperature of evaporator  $T2$  has no change or very little change

## 10.4 Operation Modes and Functions

### 10.4.1 Fan mode

- (1) Outdoor fan and compressor stop.
- (2) Temperature setting function is disabled, and no setting temperature is displayed.
- (3) Indoor fan can be set to high/med/low/auto.
- (4) The louver operates same as in cooling mode.
- (5) Auto fan:

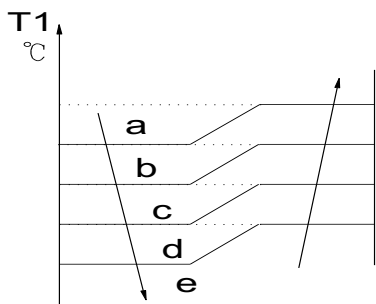

### 10.4.2 Cooling Mode

#### 10.4.2.1 Compressor running rules

When  $T1 - T_s < \Delta T - 2^\circ\text{C}$ , the compressor will stop,  
 when  $T1 - T_s > \Delta T$ , the compressor will be activated.

$\Delta T$  is the programmed parameter of temperature compensation.

When the AC run in mute mode, the compressor will run with low frequency.

When the current is more than setting value, the current protection function will be activated, and the compressor will stop.

#### 10.4.2.2 Outdoor fan running rules

The outdoor unit will be run at different fan speed according to T4.

For different outdoor units, the fan speeds are different.

For P9MVI32-09WiFi, P9MVI32-12WiFi models,

The fan speed is controlled by T4 and compressor frequency.

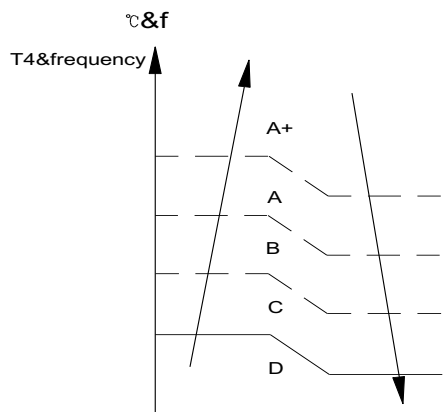

For P9MVI32-18WiFi, P9MVI32-24WiFi models,

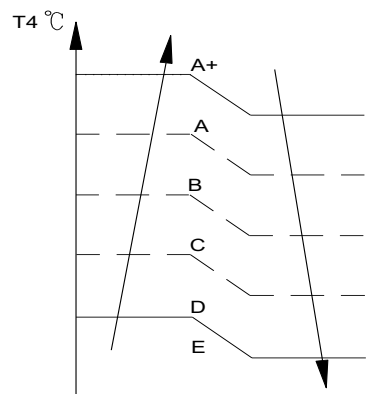

#### 10.4.2.3 Indoor fan running rules

In cooling mode, indoor fan runs all the time and the speed can be selected as high, medium, low, auto and mute.

When the setting temperature is reached, if the compressor stop running, indoor fan motor will run in Minimum speed or setting speed.

The indoor fan is controlled as below:

$$T_d = T_s + \Delta t$$

Setting fan speed	T1-Td (°C/°F)	Actual fan speed
H	A	H+ (H+=H+G)
	B	H (=H)
	C	H- (H-=H-G)
M	D	M+ (M+=M+Z)
	E	M (M=M)
	F	M- (M-=M-Z)
L	G	L+ (L+=L+D)
	H	L (L=L)
	I	L- (L-=L-D)

The auto fan acts as below rules:

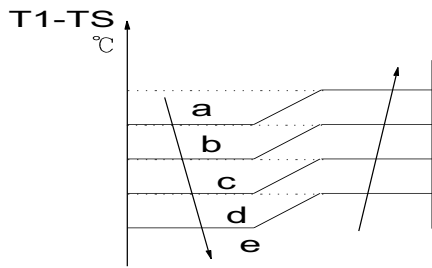

**10.4.2.4 Condenser temperature protection**

For 9k,12k models,

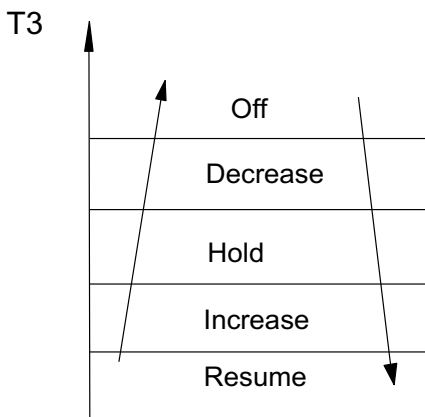

For 18k, 24k models,

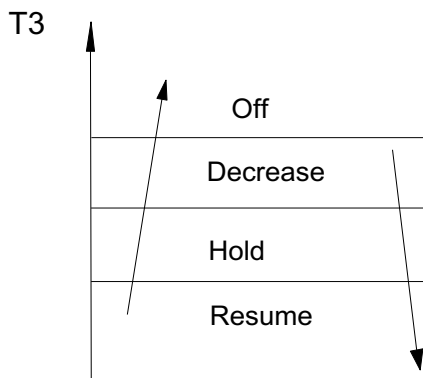

When condenser temperature is more than setting value, the compressor will stop.

**10.4.2.5 Evaporator temperature protection**

When Evaporator temperature is less than setting value, the compressor will stop.

**10.4.3 Heating Mode**

**10.4.3.1 Compressor running rules**

When  $T1-T_s > \Delta T$ , the compressor will stop,  
 when  $T1-T_s < \Delta T - 1$ , the compressor will be on.

$\Delta T$  is the programmed parameter of temperature compensation.

When the AC run in mute mode, the compressor will run with low frequency.

When the current is more than setting value, the current protection function will be activated and the compressor will stop.

**10.4.3.2 Outdoor fan running rules**

The outdoor unit will be run at different fan speed according to  $T4$ .

For different outdoor units, the fan speeds are different.

For 9k,12k models,

The fan speed is controlled by  $T4$  and compressor frequency.

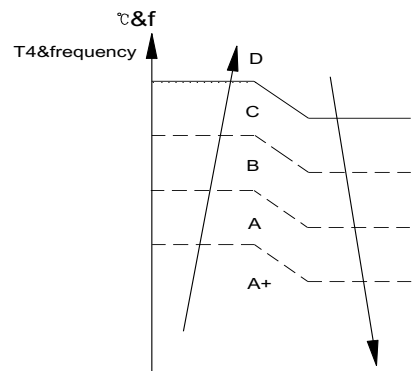

For 18k,24k models,

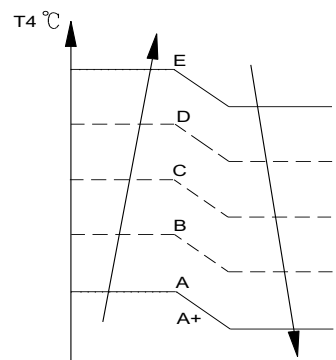



### 10.4.3.3 Indoor fan running rules

When the compressor is on, the indoor fan can be set to high/med/low/auto/mute.

When indoor unit coil temperature is low, the anti-cold air function will start and indoor fan motor will run at low speed, the speed can't be changed, when the temperature is lower than setting value, the indoor fan motor will stop.

When the indoor temp reaches the setting temperature, the compressor will stop, the indoor fan motor will run at the minimum speed or setting speed. (The anti-cold air function is valid).

The indoor fan is controlled as below:

$$T_d = T_s + \Delta t$$

Setting fan speed	$T_1 - T_d$ °C	Actual fan speed
H		H+ (H=H+G)
		H (=H)
		H- (H=H-G)
M		M+ (M=M+Z)
		M (M=M)
		M- (M=M-Z)
L		L- (L=L-D)
		L (L=L)
		L+ (L=L+D)

Auto fan action in heating mode:

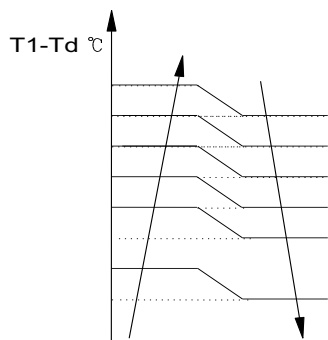

### 10.4.3.4 Defrosting mode

For 9k, 12k models, AC will enter the defrosting mode according to the value of temperature of T3 and the value of temperature of T4 and also the compressor running time. During the defrosting mode, the compressor keep running, indoor and

outdoor motor will stop, defrost lamp of the indoor unit will be lighted "dF." will be displayed.

If any one of the following items is satisfied, the defrosting will finish and the machine will turn to normal heating mode.

----T3 rises to be higher than TCDE1°C.

----T3 keeps to be higher than TCDE2°C for 80 seconds.

----The machine has run for 15 minutes in defrosting mode.

For 18k, 24k models,

AC will enter the defrosting mode according to the value of temperature of T3 and the value range of temperature change of T3 and also the compressor running time.

During the defrosting mode, the compressor keep running, indoor and outdoor motor will stop, defrost lamp of

the indoor unit will be lighted "dF." Will be displayed. If any one of the following items is satisfied, the defrosting will finish and the machine will turn to normal heating mode.

----T3 rises to be higher than TCDE1°C.

----T3 keeps to be higher than TCDE2°C for 80 seconds.

----The machine has run for 10 minutes in defrosting mode.

### 10.4.3.5 Evaporator coil temperature protection

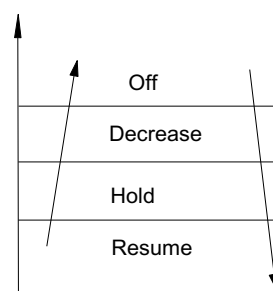

When evaporator temperature is more than the setting protection value, the compressor will stop.

#### 10.4.4 Auto-mode

This mode can be chosen with remote controller and the setting temperature can be changed between 17°C~30°C. In auto mode, the machine will choose cooling, heating or fan-only mode according to  $\Delta T$  ( $\Delta T = T1 - Ts$ ).

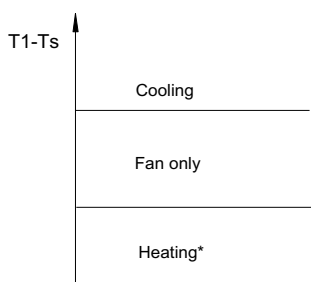

**Heating\*:** For cooling only models, they will run at fan speed. Indoor fan will run at auto fan of the relevant mode. The louver operates same as in relevant mode. If the machine switches mode between heating and cooling, the compressor will keep stopping for certain time and then choose mode according to  $T1 - Ts$ . If the setting temperature is modified, the machine will choose running function again.

#### 10.4.5 Drying mode

Indoor fan speed is fixed at breeze and can't be changed. The louver angle is the same as in cooling mode. All protections are active and the same as that in cooling mode.

#### 9.4.6 Forced operation function

**Forced cooling mode:**

The compressor and outdoor fan keep running and the indoor fan runs at low speed. After running for 30 minutes, AC

will turn to auto mode with 24°C setting temperature.

**Forced auto mode:**

The action of forced auto mode is the same as normal auto mode with 24°C setting temperature.

When AC receives signals, such as switch on, switch off, timer on, timer off, mode setting, fan speed setting, sleeping mode setting, follow me setting, it will quit the forced operation.

#### 10.4.7 Sleep function

10.4.7.1 The sleep function is available in cooling, heating or auto mode.

10.4.7.2. Operation process in sleep mode is as follow:

When cooling, the setting temperature rises 1°C (be lower than 30°C) every one hour, 2 hours later the setting temperature stops rising and the indoor fan is fixed at low speed.

When heating, the setting temperature decreases 1°C (be higher than 17°C) every one hour, 2 hours later the setting temperature stops rising and indoor fan is fixed at low speed. (Anti-cold wind function has the priority).

10.4.7.3 Operation time in sleep mode is 7 hours. After 7 hours the AC quits this mode and turns off.

10.4.7.4 Timer setting is available

#### 10.4.8 Auto-Restart function

The indoor unit is equipped with auto-restart function, which is carried out through an auto-restart module. In case of a sudden power failure, the module memorizes the setting conditions before the power failure. The unit will resume the previous operation setting (not including swing function) automatically after 3 minutes when power returns.

If the memorization condition is forced cooling mode, the unit will run in cooling mode for 30 minutes and turn to auto mode as 24°C setting temperature. If AC is off before power off and AC is required to start up now, the compressor will have 1 minute delay when power on. Other conditions, the compressor will have 3 minutes delay when restarts.

#### **10.4.9 Refrigerant Leakage Detection**

With this new technology, the display area will show "EC" when the outdoor unit detects refrigerant leakage.

#### **10.4.10 8°C Heating(optional)**

In heating operation, the preset temperature of the air conditioner can be as low as 8°C, which keeps the room temperature steady at 8°C and prevents household things freezing when the house is unoccupied for a long time in severe cold weather.

#### **10.4.11 Self clean(optional)**

For heat pump models which are provided with this function, after running in cooling or drying mode, if the user press "Self Clean" button on remote controller, firstly, indoor unit runs in fan only mode for a while, then low heat operation and finally runs in fan only again. This function can keep the inside of indoor unit dry and prevent breeding of mold.

#### **10.4.12 Follow me(optional)**

1) If the indoor PCB receives the signal which results from pressing the FOLLOW ME button on remote controller, the buzzer will emit a sound and this indicates the follow me function is initiated. But when the indoor PCB receives signal which

sent from remote controller every 3 minutes, the buzzer will not respond.

When the unit is running with follow me function, the PCB will control the unit according to the temperature from follow me signal, and the temperature collection function of room temperature sensor will be shielded, but the error detective function of room temperature sensor will be still valid.

2) When the follow me function is available,

the PCB will control the unit according to the room temperature from the remote controller and the setting temperature.

3) The PCB will take action to the mode change information from remote controller signal, but it will not be affected by the setting temperature.

4) When the unit is running with follow me

function, if the PCB doesn't receive any signal from remote controller for 7 minutes or pressing FOLLOW ME button again, the follow me function will be turned off automatically, and the temperature will control the unit according to the room temperature detected from its own room temperature sensor and setting temperature.

#### **10.4.13 Silence operation(optional)**

Press the "silence" button on remote controller to initiate SILENCE function. When the Silence function is activated, the compressor running frequency will keep lower than F2 and the indoor unit will bring faint breeze, which will reduce the noise to the lowest level and create a quiet and comfortable room for you.

#### **10.4.14 Easy control(optional)**

For AE series, On-off port, XYE port, WIFI, wired controller(5-cored) can be chosen at the same time. Non-polar wired controller,4-cored wired controller, and central controller are mutually exclusive.

### 10.4.15 Point check function

Press the LED DISPLAY or LED or MUTE button of the remote controller three times, and then press the AIR DIRECTION or SWING button three times in ten seconds, the buzzer will keep ring for two seconds. The air conditioner will enter into the information enquiry status. You can press the LED DISPLAY or AIR DIRECTION button to check the next or front item's information.

When the AC enter the "information enquiry" status, it will display the code name in 2 seconds, the details are as follows.

Enquiry information	Displaying code	Meaning
T1	T1	Indoor room temperature
T2	T2	Indoor coil mid temperature
T3	T3	Outdoor coil temperature
T4	T4	Outdoor temperature
T2B	Tb	Indoor coil outlet temperature
TP	TP	Compressor discharge temp
TH	TH	IPM modular temperature
Targeted Frequency	FT	Targeted Frequency
Actual Frequency	Fr	Actual Frequency
Indoor fan speed	IF	Indoor fan speed
Outdoor fan speed	OF	Outdoor fan speed
EXV opening angle	LA	EXV opening angle
Compressor continuous running time	CT	Compressor continuous running time
Causes of compressor stop.	ST	Causes of compressor stop.
Reserve	A0	
Reserve	A1	
Reserve	b0	
Reserve	b1	
Reserve	b2	
Reserve	b3	
Reserve	b4	
Reserve	b5	
Reserve	b6	
Reserve	dL	
Reserve	Ac	
Reserve	Uo	
Reserve	Td	
Reserve	dA	

Reserve	dS	
Reserve	dT	

When the AC enter into the information enquiry status, it will display the code value in the next 25s, the details are as follows.

Enquiry information	Display value	Meaning	Remark
T1,T2,T3,T4, T2B,TP,TH, Targeted Frequency, Actual Frequency	-1F,-1E,-1d,-1c,- 1b,-1A	-25,-24,-23,-22,-21,-2 0	1. All the displaying temperature is actual value. 2. All the temperature is °C no matter what kind of remote controller is used. 3. T1,T2,T3,T4,T2B display range:-25~70, TP display range:-20~130. 4. Frequency display range: 0~159HZ. 5. If the actual value exceeds the range, it will display the maximum value or minimum value.
	-19—99	-19—99	
	A0,A1,...A9	100,101,...109	
	b0,b1,...b9	110,111,...119	
	c0,c1,...c9	120,121,...129	
	d0,d1,...d9	130,131,...139	
	E0,E1,...E9	140,141,...149	
	F0,F1,...F9	150,151,...159	
Indoor fan speed /Outdoor fan speed	0	OFF	
	1,2,3,4	Low speed, Medium speed, High speed, Turbo	For some big capacity motors.
	14-FF	Actual fan speed=Display value turns to decimal value and then multiply 10. The unit is RPM.	For some small capacity motors, display value is from 14-FF(hexadecimal), the corresponding fan speed range is from 200-2550RPM.
EXV opening angle	0-FF	Actual EXV opening value=Display value turns to decimal value and then multiply 2.	
Compressor continuous running time	0-FF	0-255 minutes	If the actual value exceeds the range, it will display the maximum value or minimum value.
Causes of compressor stop.	0-99	For the detailed meaning, please consult with engineer	Decimal display
Reserve	0-FF		
Reserve	2~28		
Reserve	5~20		
Reserve	5~25		

## 10.5 Multi-function board instruction (This multi-function board is optional)

### 10.5.1. Function

The multi-function board receives the signal of 4-cored wired controller(central controller),Non-polar wired controller and CP remote on-off signal( ON-OFF command signal). Then converting it to the communication signal to the main control board.

The multi-function board can output Alarm signal.

The multi-function board has two versions, one for Non-polar wired controller, the other one for 4-cored wired controller or central controller.

### 10.5.2. CP remote on-off

10.5.2.1 This is the same as the LCAC, that is to say for the first time, when you active this function, you need firstly use remote controller to turn on the unit .After setting, when the unit are running, you can use the on-off function to turn off the units and display will show CP, when you use this function again, the display will cancel CP and the unit will run as the last situation.

10.5.2.2 If need this function, the switches F2 should be settled as below:

Dip-switch 2	Dip-switch 1	Remote on-off control status
OFF	OFF	Disconnected send CP, closed cancel CP
ON	OFF	Closed send CP, disconnected cancel CP

### 10.5.3. ON-OFF control

10.5.3.1 With on-off command, you can directly use this function regardless remote controller.The indoor will be turned on and off by this port. But indoor will still get order from remote controller when it is turned off by this port. when the indoor is turned on by this port, the unit will run in Auto mode ,Auto fan speed, 24℃ setting temperature

10.5.3.2 If need this function, the switches F2 should be settled as below:

Dip-switch 2	Dip-switch 1	Remote on-off control status
OFF	ON	Disconnected send ON, closed send OFF
ON	ON	Closed send OFF, disconnected send ON

### 10.5.4. 4-cored wired controller, Central controller and Non-polar wired controller

Note: 4-cored wired controller, Central controller and Non-polar wired controller are mutually exclusive. They can only be chosen one of three at the same time.

10.5.4.1 For network address, Dip-switch F1 and Rotary switch ENC3 are set as below:

Dip-switch 2	Dip-switch 1	Based address
OFF	OFF	0
OFF	ON	16
ON	OFF	32
ON	ON	48

Note: The network address are the Dip-switch F1 address plus Rotary switch ENC3 address.

10.5.4.2 If it receives the network address set by remote controller, the network address will be changed .If it receives the cancel signal of network address set by remote controller, the network address will be disposed according to the setting of Dip-switch F1 and Rotary switch ENC3.

10.5.4.3 The network address is useless for 4-cored wired controller, only valid for Central controller and Non-polar wired controller.

**10.5.5. Non-polar wired controller**

10.5.1 Each Non-polar wired controller can be connect to Max. 16 indoor units .All the indoor units must be the same series, and in the same network. The address of Multi-function board must be set differently. The connection method must be Bus type.

10.5.2 The setting state are the same for all the indoor units connected to the same Non-polar wired controller

**10.5.6. Alarm port output**

10.5.6.1 When the Air-condition in off state, the output signal is closed.

10.5.6.2 When the Air-condition in malfunction state, the output signal is closed.

10.5.6.3 When the Air-condition in on state, the output signal is disconnected.

**10.5.7. Wiring diagram**

10.5.7.1 Connected to 4-cored wired controller or Central controller

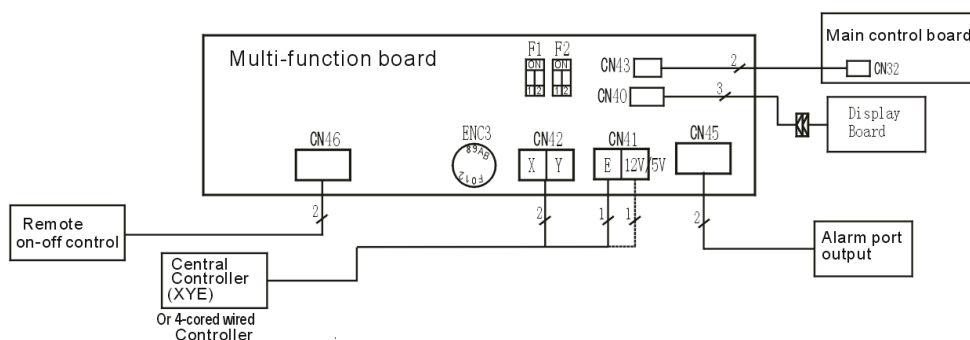

Note: It must use shield cables to connect with 4-cored wired controller and Central controller.

The length should not exceed 50m.



### 10.5.7.2 Connected to Non-polar wired controller

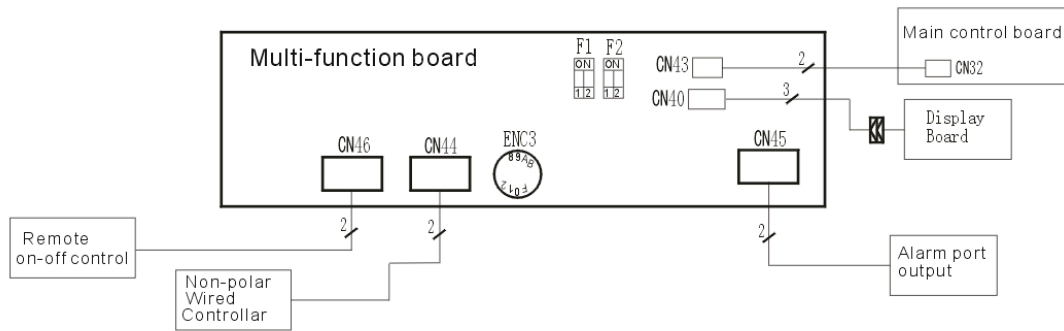

Note: It must use shield cables to connect with Non-polar wired controller.  
The length should not exceed 5

# 11. Troubleshooting

## Safety

Electricity power is still kept in capacitors even the power supply is shut off. Do not forget to discharge the electricity power in capacitor.

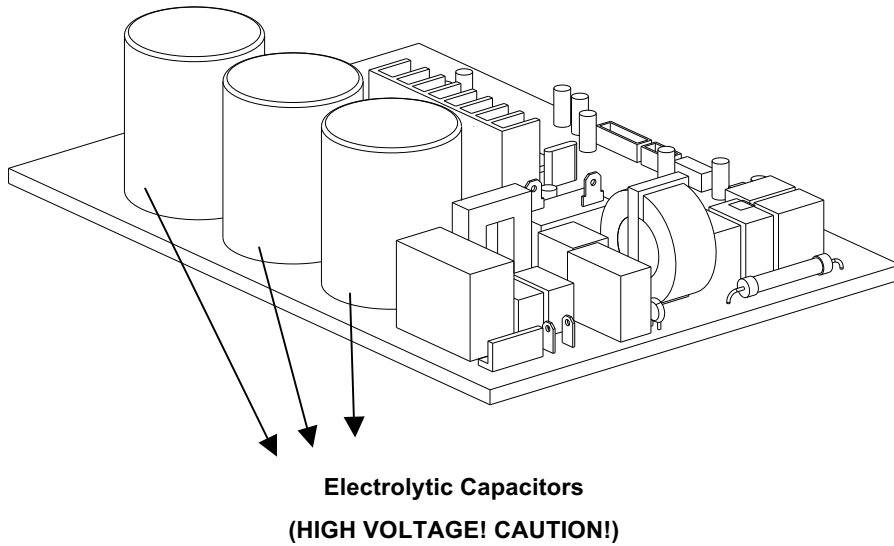

For other models, please connect discharge resistance (approx.100Ω 40W) or soldering iron (plug) between +, - terminals of the electrolytic capacitor on the contrary side of the outdoor PCB.

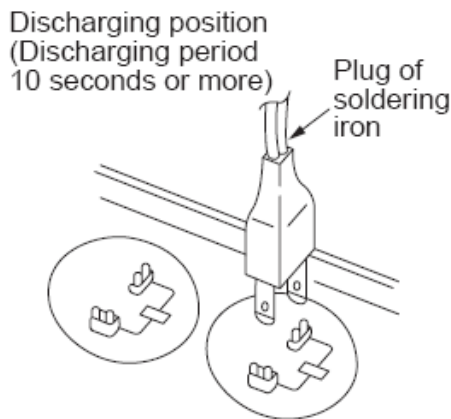

**Note: The picture above is only for reference. The plug of your side may be different.**

## 11.1 Indoor Unit Error Display

Operation lamp	Timer lamp	Display	LED STATUS
☆ 1 time	X	E0	Indoor unit EEPROM parameter error
☆ 2 times	X	E1	Indoor / outdoor units communication error
☆ 4 times	X	E3	Indoor fan speed has been out of control
☆ 5 times	X	E4	Indoor room temperature sensor T1 open circuit or short circuit
☆ 6 times	X	E5	Evaporator coil temperature sensor T2 open circuit or short circuit
☆ 9 times	X	E7	Indoor PCB /Display board communication error
☆ 7 times	X	EC	Refrigerant leakage detection
☆ 1 times	O	F0	Overload current protection
☆ 2 times	O	F1	Outdoor ambient temperature sensor T4 open circuit or short circuit
☆ 3 times	O	F2	Condenser coil temperature sensor T3 open circuit or short circuit
☆ 4 times	O	F3	Compressor discharge temperature sensor T5 open circuit or short circuit
☆ 5 times	O	F4	Outdoor unit EEPROM parameter error
☆ 6 times	O	F5	Outdoor fan speed has been out of control
☆ 1 times	☆	P0	IPM malfunction or IGBT over-strong current protection
☆ 2 times	☆	P1	Over voltage or over low voltage protection
☆ 3 times	☆	P2	High temperature protection of IPM module
☆ 5 times	☆	P4	Inverter compressor drive error

O (light)

X (off)

☆ (flash)

## 11.2 Trouble shooting

### 11.2.1 EEPROM parameter error diagnosis and solution(E0/F4)

Error Code	<b>E0/F4</b>
Malfunction decision conditions	Indoor or outdoor PCB main chip does not receive feedback from EEPROM chip.
Supposed causes	<ul style="list-style-type: none"><li>● Installation mistake</li><li>● PCB faulty</li></ul>

#### Trouble shooting:

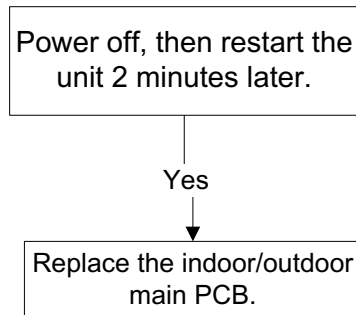

EEPROM: a read-only memory whose contents can be erased and reprogrammed using a pulsed voltage. For the location of EEPROM chip, please refer to the below photos.

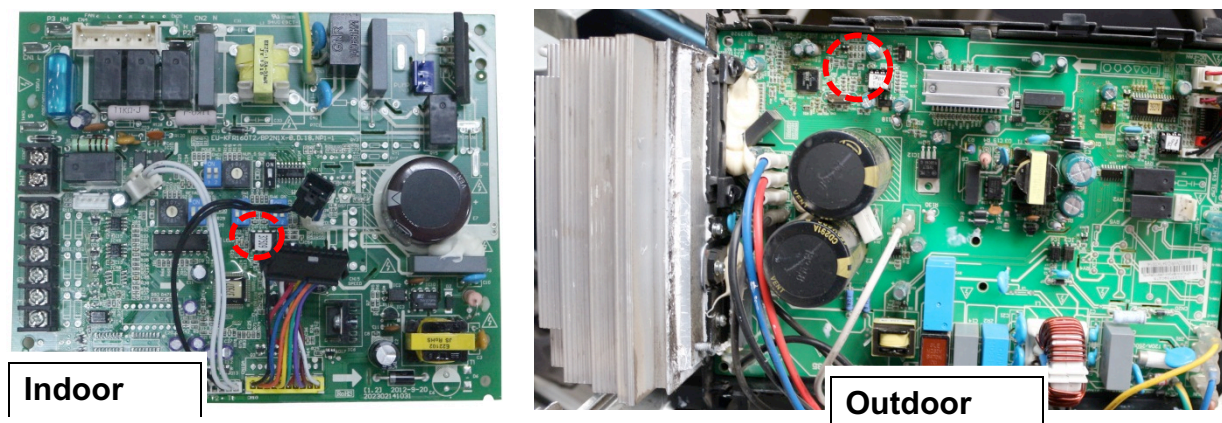

**Note:** The two photos above are only for reference, it's may be not same totally with the ones on your side.

### 11.2.2 Indoor / outdoor unit's communication diagnosis and solution(E1)

Error Code	<b>E1</b>
Malfunction decision conditions	Indoor unit does not receive the feedback from outdoor unit during <b>110</b> seconds and this condition happens four times continuously.
Supposed causes	<ul style="list-style-type: none"> <li>● Wiring mistake</li> <li>● Indoor or outdoor PCB faulty</li> </ul>

#### Trouble shooting:

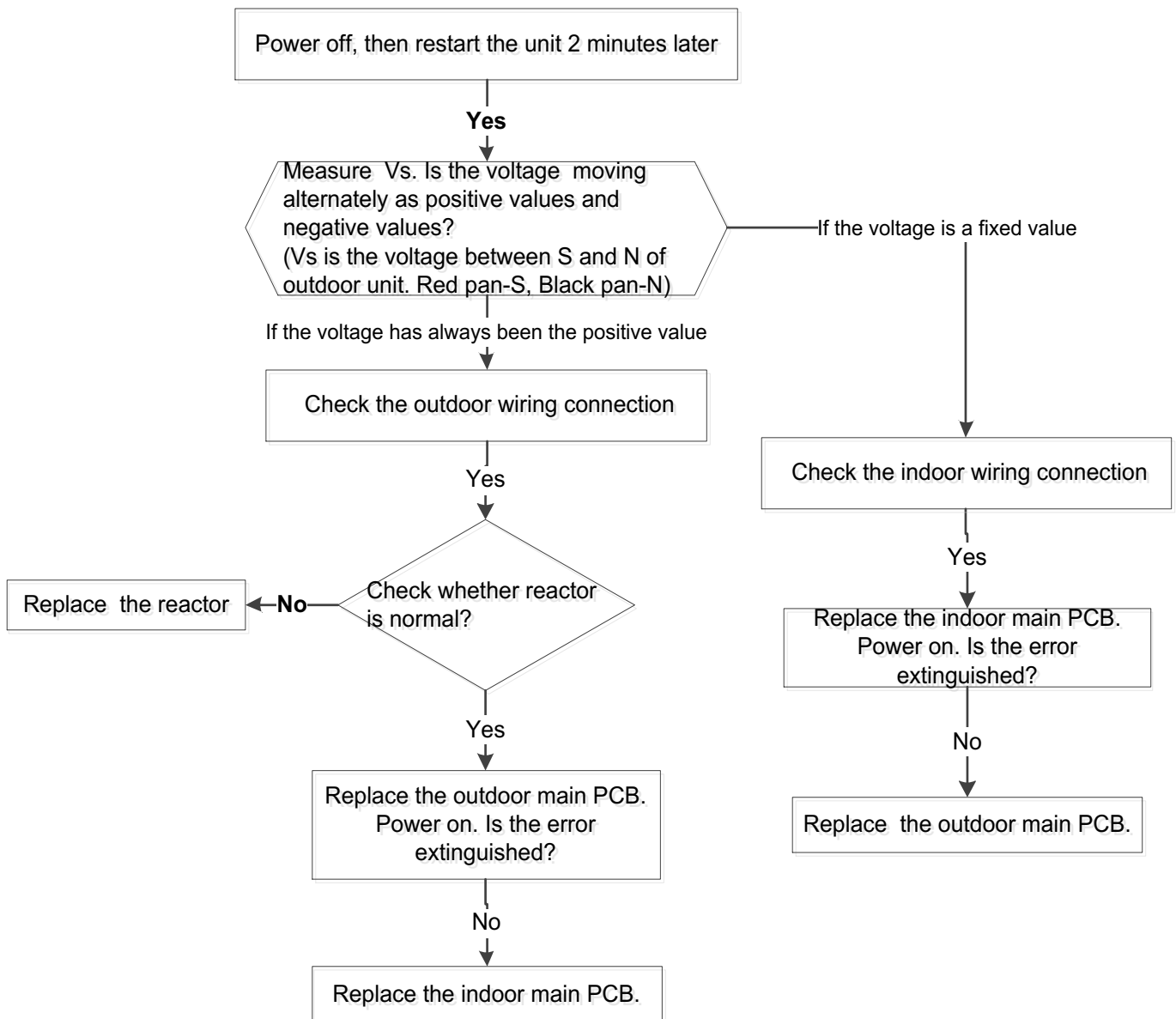

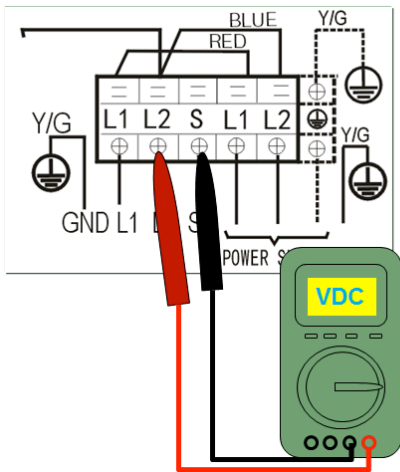

*S and N  
or  
L2 and S  
Or  
2 and 3*

**Remark:**

Use a multimeter to test the DC voltage between 2 port and 3 port of outdoor unit. The red pin of multimeter connects with 2 port while the black pin is for 3 port.

When AC is normal running, the voltage is moving alternately as positive values and negative values

If the outdoor unit has malfunction, the voltage has always been the positive value

While if the indoor unit has



**Remark:**

Use a multi meter to test the resistance of the reactor which does not connect with capacitor. The normal value should be around zero ohm. Otherwise, the reactor must have malfunction and need to

### 11.2.4 Fan speed has been out of control diagnosis and solution (E3)

<b>Error Code</b>	<b>E3/F5</b>
<b>Malfunction decision conditions</b>	<b>When indoor fan speed keeps too low (300RPM) for certain time, the unit will stop and the LED will display the failure.</b>
<b>Supposed causes</b>	<ul style="list-style-type: none"> <li>● Wiring mistake</li> <li>● Fan ass'y faulty</li> <li>● Fan motor faulty</li> <li>● PCB faulty</li> </ul>

#### Trouble shooting:

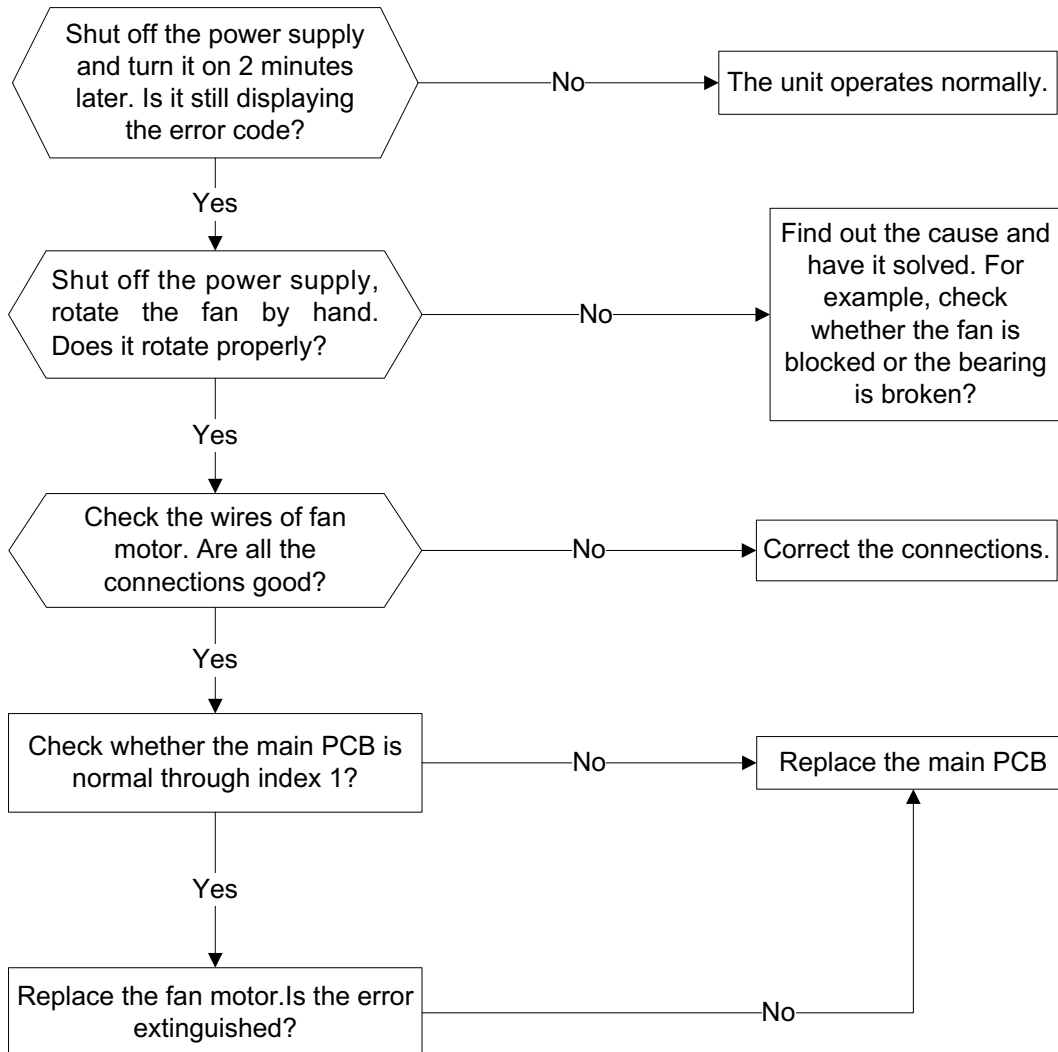

Index1:

1:Indoor or Outdoor DC Fan Motor(control chip is in fan motor)

Power on and when the unit is in standby, measure the voltage of pin1-pin3, pin4-pin3 in fan motor connector. If the value of the voltage is not in the range showing in below table, the PCB must has problems and need to be replaced.

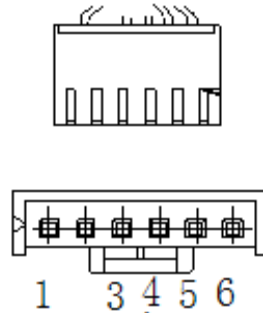

DC motor voltage input and output

NO.	Color	Signal	Voltage
1	Red	Vs/Vm	280V~380V
2	---	---	---
3	Black	GND	0V
4	White	Vcc	14-17.5V
5	Yellow	Vsp	0~5.6V
6	Blue	FG	14-17.5V

2. Outdoor DC Fan Motor (control chip is in outdoor PCB)

Power on ,and check if the fan can run normally, if the fan can run normally, the PCB must has problems and need to be replaced, If the fan can't run normally, measure the resistance of each two pins. If the resistance is not equal to each other, the fan motor must have problems and need to be replaced, otherwise the PCB must has problems and need to be replaced.



### 11.2.4 Refrigerant Leakage Detection diagnosis and solution(EC)

<b>Error Code</b>	<b>EC</b>
<b>Malfunction decision conditions</b>	<p>Define the evaporator coil temperature <math>T_2</math> of the compressor just starts running as <math>T_{cool}</math>.</p> <p>In the beginning 8 minutes after the compressor starts up, if <math>T_2 &lt; T_{cool} - 2^\circ\text{C}</math> does not keep continuous 4 seconds and compressor running frequency higher than 50Hz does not keep continuous 3 minutes, and this situation happens 3 times, the display area will show "EC" and AC will turn off.</p>
<b>Supposed causes</b>	<ul style="list-style-type: none"> <li>● T2 sensor faulty</li> <li>● Indoor PCB faulty</li> <li>● System problems, such as leakage or blocking.</li> </ul>

#### Trouble shooting:

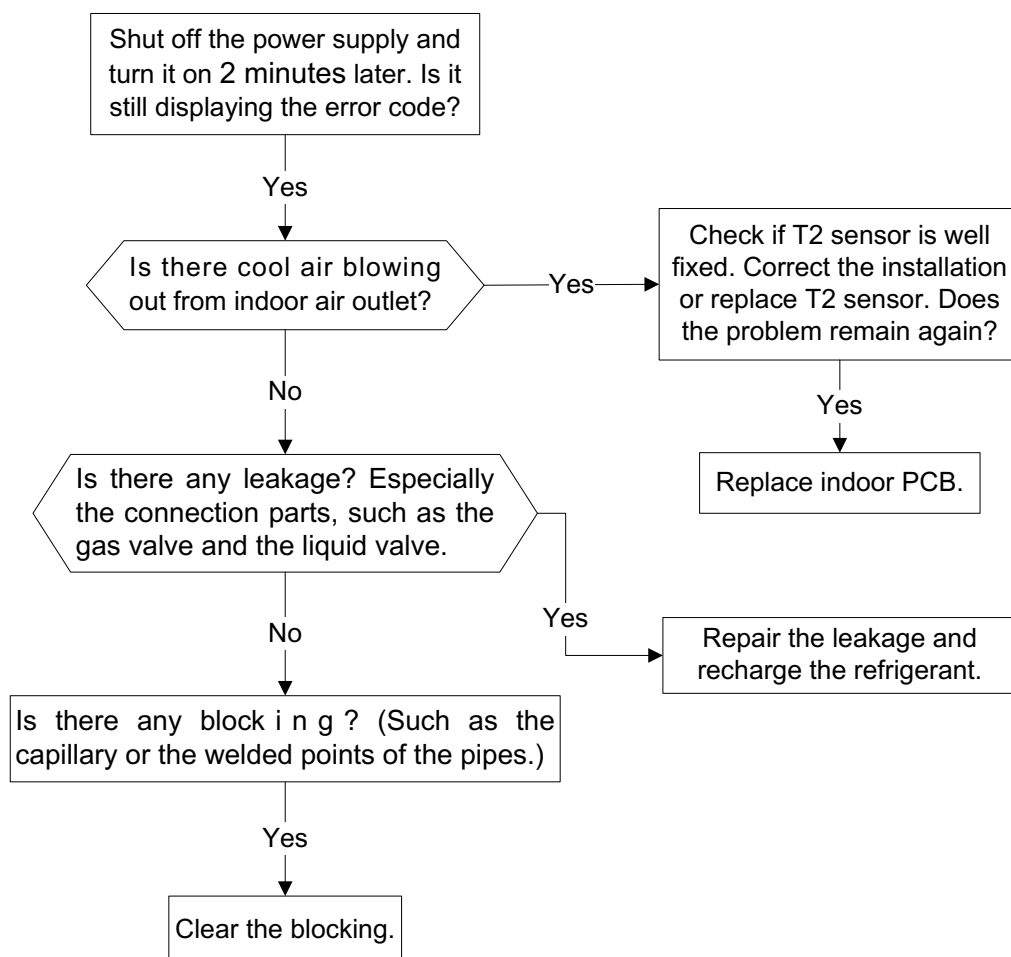

### 11.2.5 Open circuit or short circuit of temperature sensor diagnosis and solution (E4/E5/F1/F2/F3)

<b>Error Code</b>	<b>E4/E5/F1/F2/F3</b>
<b>Malfunction decision conditions</b>	If the sampling voltage is lower than 0.06V or higher than 4.94V, the LED will display the failure.
<b>Supposed causes</b>	<ul style="list-style-type: none"> <li>● Wiring mistake</li> <li>● Sensor faulty</li> <li>● PCB faulty</li> </ul>

#### Trouble shooting:

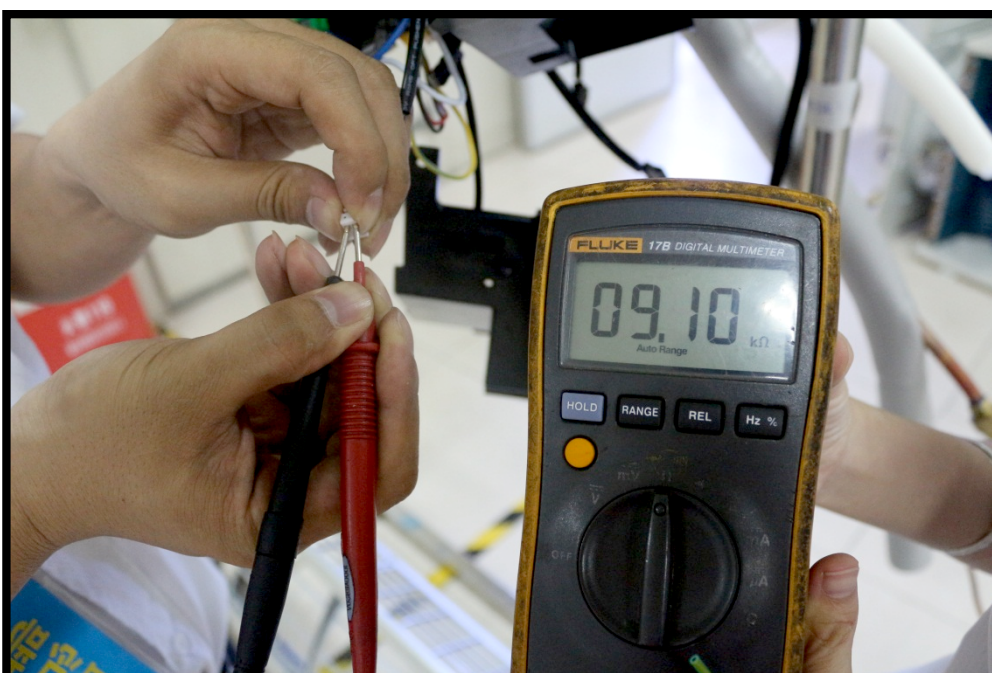
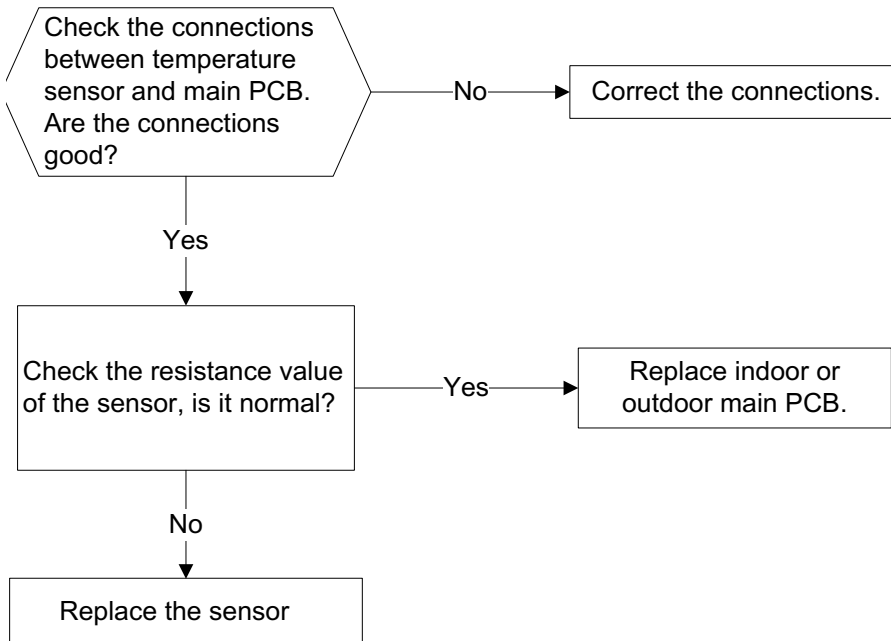

### 11.2.6 Overload current protection diagnosis and solution(F0)

<b>Error Code</b>	<b>F0</b>
<b>Malfunction decision conditions</b>	<b>An abnormal current rise is detected by checking the specified current detection circuit.</b>
<b>Supposed causes</b>	<ul style="list-style-type: none"> <li>● <b>Power supply problems.</b></li> <li>● <b>System blockage</b></li> <li>● <b>PCB faulty</b></li> <li>● <b>Wiring mistake</b></li> <li>● <b>Compressor malfunction</b></li> </ul>

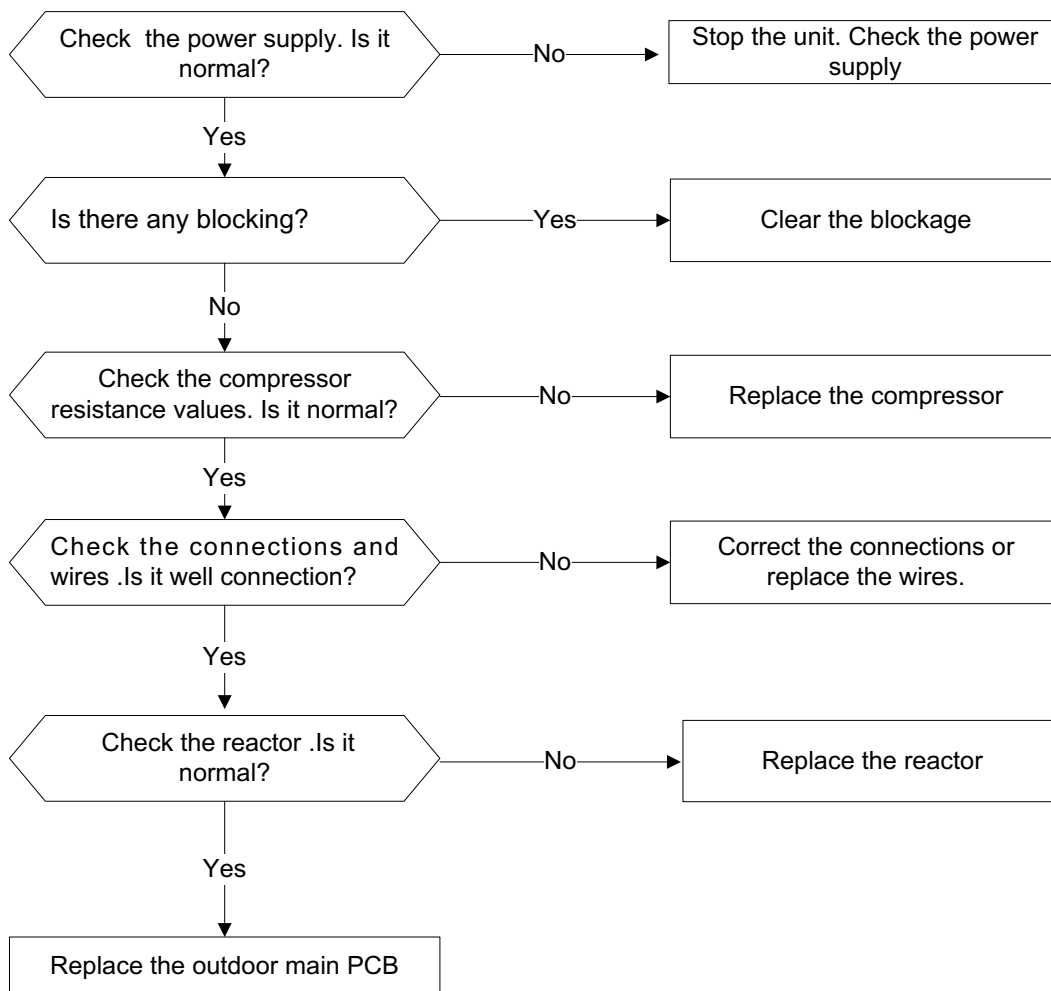

### 11.2.7 IPM malfunction or IGBT over-strong current protection diagnosis and solution(P0)

<b>Error Code</b>	<b>P0</b>
<b>Malfunction decision conditions</b>	When the voltage signal that IPM send to compressor drive chip is abnormal, the display LED will show “P0” and AC will turn off.
<b>Supposed causes</b>	<ul style="list-style-type: none"> <li>● <b>Wiring mistake</b></li> <li>● <b>IPM malfunction</b></li> <li>● <b>Outdoor fan ass'y faulty</b></li> <li>● <b>Compressor malfunction</b></li> <li>● <b>Outdoor PCB faulty</b></li> </ul>

#### Trouble shooting:

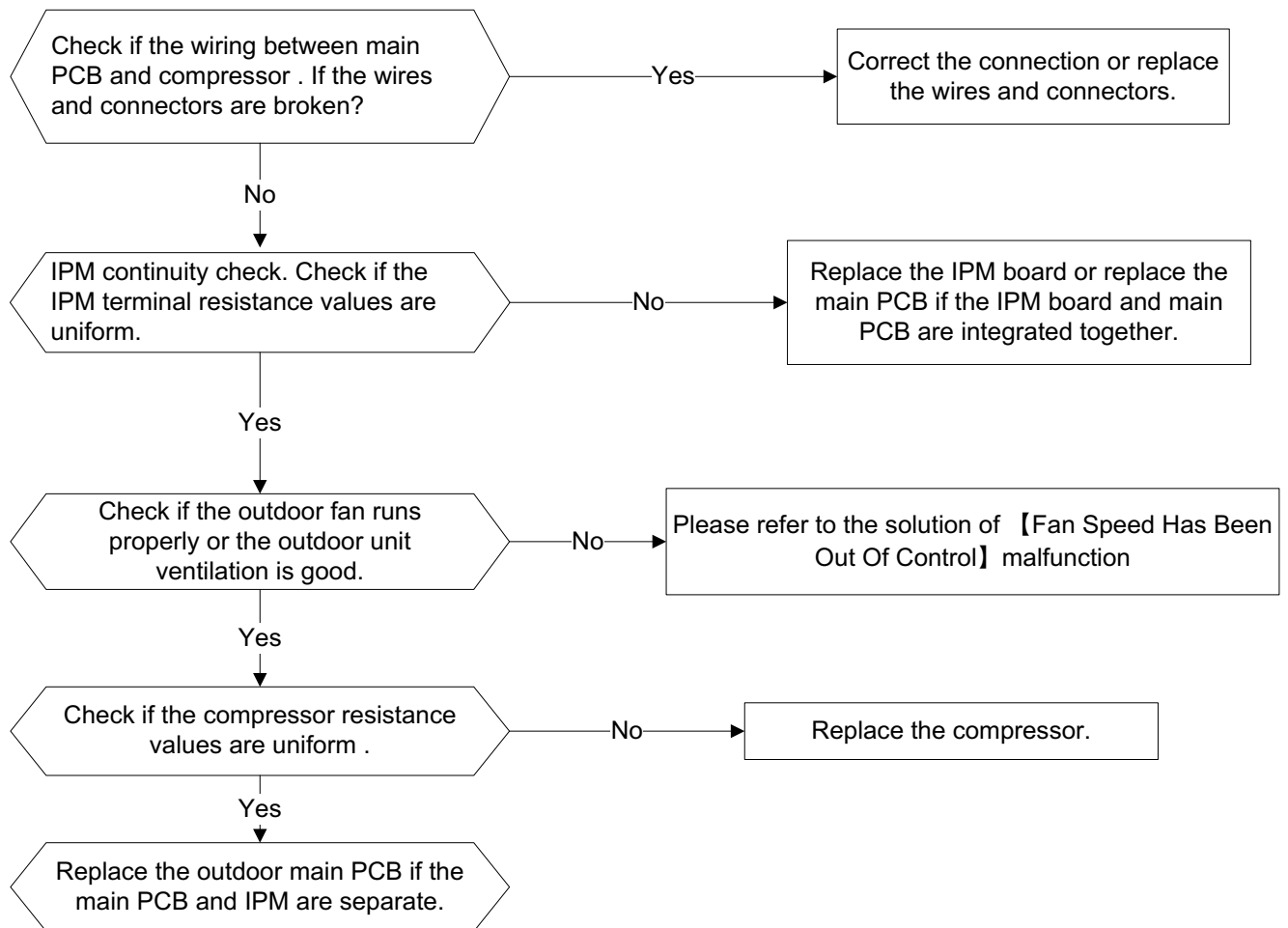

➤ **IPM continuity check**

Turn off the power, let the large capacity electrolytic capacitors discharge completely, and dismount the IPM. Use a digital tester to measure the resistance between P and UVWN; UVW and N.

Digital tester		Normal resistance value	Digital tester		Normal resistance value
(+)Red	(-)Black		(+)Red	(-)Black	
P	N	∞ (Several MΩ)	U	N	∞ (Several MΩ)
	U		V		
	V		W		
	W		(+)Red		

### 11.2.8 Over voltage or too low voltage protection diagnosis and solution(P1)

Error Code	P1
Malfunction decision conditions	An abnormal voltage rise or drop is detected by checking the specified voltage detection circuit.
Supposed causes	<ul style="list-style-type: none"> <li>● Power supply problems.</li> <li>● System leakage or block</li> <li>● PCB faulty</li> </ul>

#### Trouble shooting:

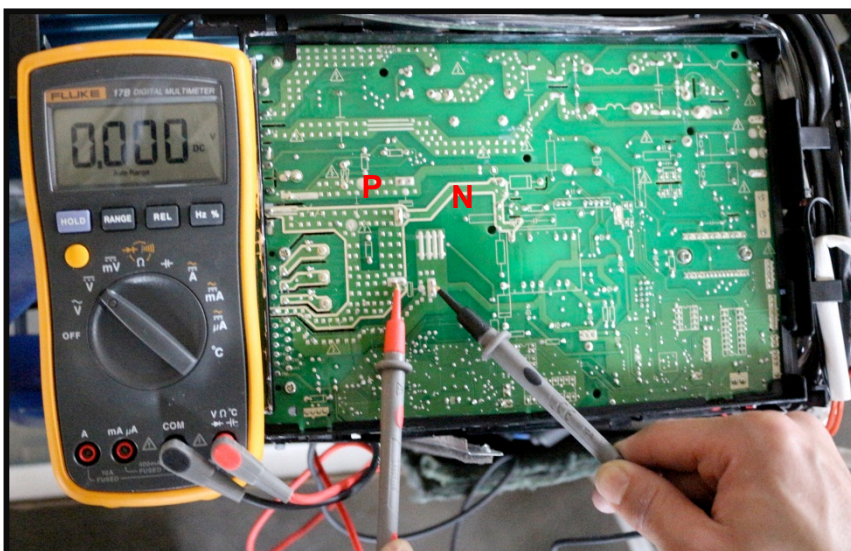
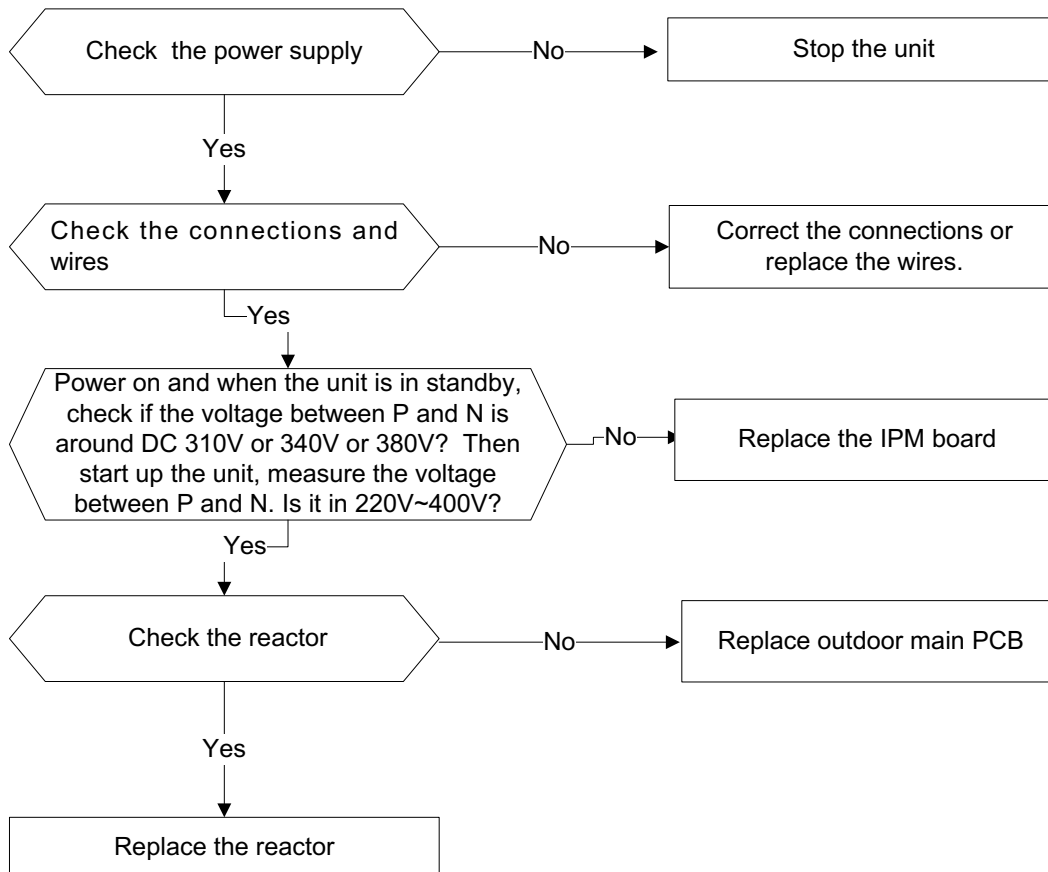

**Remark:**  
 Measure the DC voltage between P and N port. The normal value should be around 310V.

### 11.2.9 High temperature protection of IPM module diagnosis and solution (P2)

Error Code	P2
Malfunction decision conditions	If the temperature of IPM module is higher than limited value, the LED will display the failure.
Supposed causes	<ul style="list-style-type: none"><li>● IPM radiator problem</li><li>● PCB faulty</li></ul>

#### Trouble shooting:

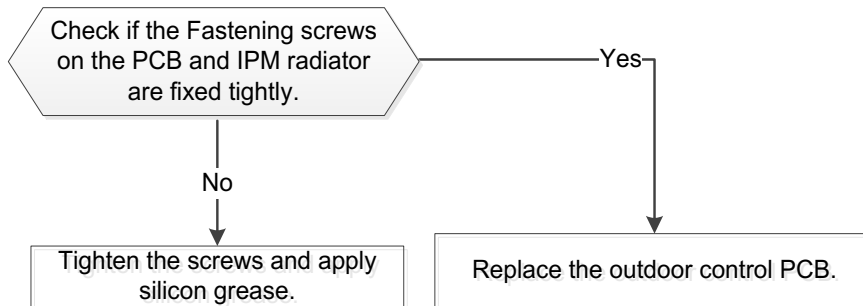

### 11.2.10 Inverter compressor drive error diagnosis and solution(P4)

<b>Error Code</b>	<b>P4</b>
<b>Malfunction decision conditions</b>	<b>An abnormal inverter compressor drive is detected by a special detection circuit, including communication signal detection, voltage detection, compressor rotation speed signal detection and so on.</b>
<b>Supposed causes</b>	<ul style="list-style-type: none"> <li>● <b>Wiring mistake</b></li> <li>● <b>IPM malfunction</b></li> <li>● <b>Outdoor fan ass'y faulty</b></li> <li>● <b>Compressor malfunction</b></li> <li>● <b>Outdoor PCB faulty</b></li> </ul>

#### Trouble shooting:

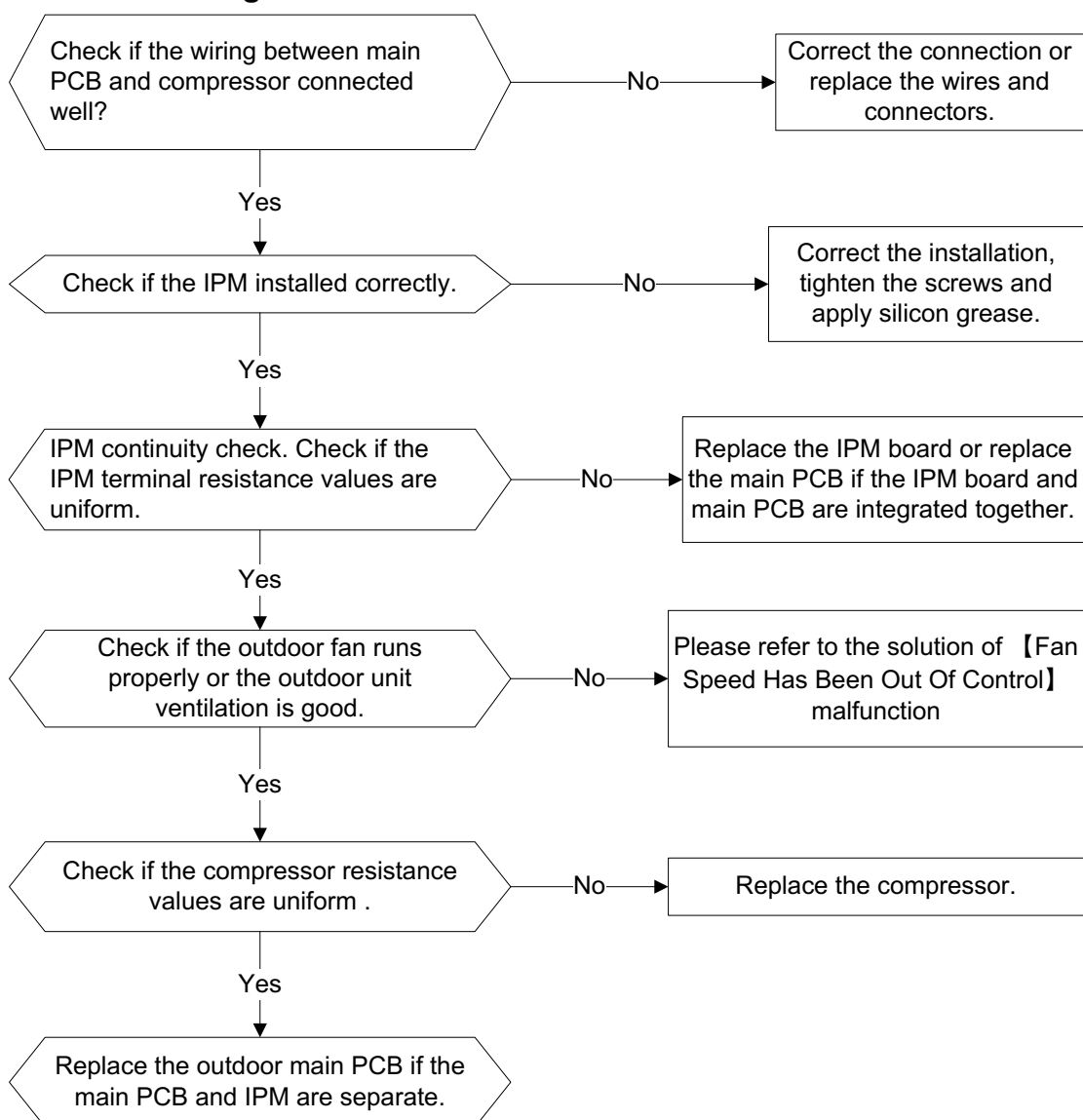



### 11.2.11 Indoor PCB /Display board communication error (E7)

<b>Error Code</b>	<b>E7</b>
<b>Malfunction decision conditions</b>	<b>Indoor PCB does not receive feedback from Display board.</b>
<b>Supposed causes</b>	<ul style="list-style-type: none"> <li>● <b>Wiring mistake</b></li> <li>● <b>PCB faulty</b></li> <li>● <b>Display board malfunction</b></li> </ul>

**Trouble shooting:**

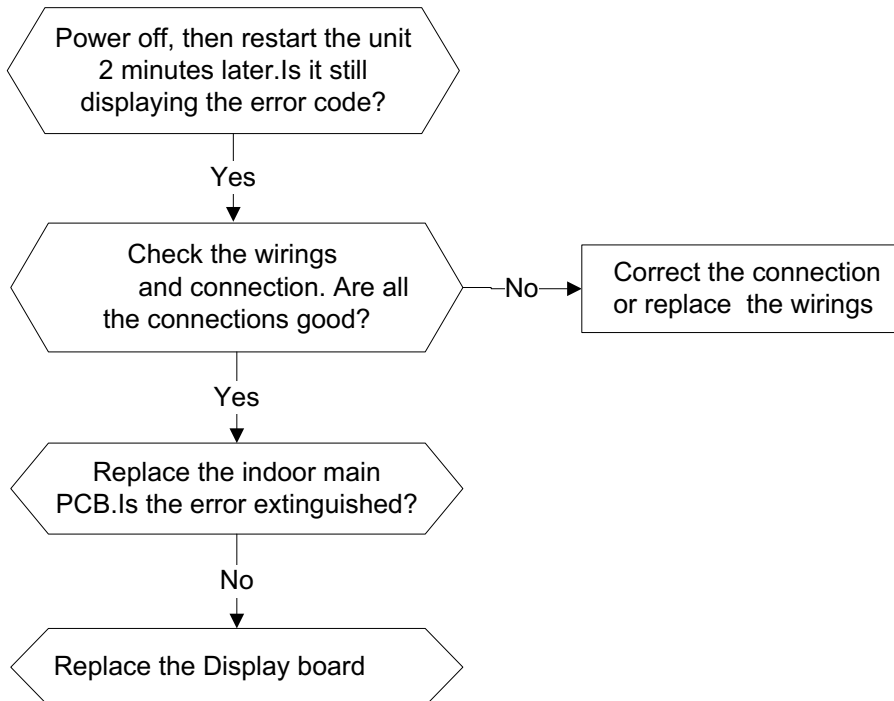

## Main parts check

### 1. Temperature sensor checking

Disconnect the temperature sensor from PCB, measure the resistance value with a tester.

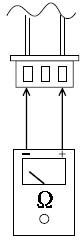

Tester

Temperature Sensors.

Room temperature(T1) sensor,

Indoor coil temperature(T2) sensor,

Outdoor coil temperature(T3) sensor,

Outdoor ambient temperature(T4) sensor,

Compressor discharge temperature(TP) sensor.

Measure the resistance value of each winding by using the multi-meter.

**Appendix 1 Temperature Sensor Resistance Value Table for T1,T2,T3,T4 (°C--K)**

°C	°F	K Ohm	°C	°F	K Ohm	°C	°F	K Ohm	°C	°F	K Ohm
-20	-4	115.266	20	68	12.6431	60	140	2.35774	100	212	0.62973
-19	-2	108.146	21	70	12.0561	61	142	2.27249	101	214	0.61148
-18	0	101.517	22	72	11.5	62	144	2.19073	102	216	0.59386
-17	1	96.3423	23	73	10.9731	63	145	2.11241	103	217	0.57683
-16	3	89.5865	24	75	10.4736	64	147	2.03732	104	219	0.56038
-15	5	84.219	25	77	10	65	149	1.96532	105	221	0.54448
-14	7	79.311	26	79	9.55074	66	151	1.89627	106	223	0.52912
-13	9	74.536	27	81	9.12445	67	153	1.83003	107	225	0.51426
-12	10	70.1698	28	82	8.71983	68	154	1.76647	108	226	0.49989
-11	12	66.0898	29	84	8.33566	69	156	1.70547	109	228	0.486
-10	14	62.2756	30	86	7.97078	70	158	1.64691	110	230	0.47256
-9	16	58.7079	31	88	7.62411	71	160	1.59068	111	232	0.45957
-8	18	56.3694	32	90	7.29464	72	162	1.53668	112	234	0.44699
-7	19	52.2438	33	91	6.98142	73	163	1.48481	113	235	0.43482
-6	21	49.3161	34	93	6.68355	74	165	1.43498	114	237	0.42304
-5	23	46.5725	35	95	6.40021	75	167	1.38703	115	239	0.41164
-4	25	44	36	97	6.13059	76	169	1.34105	116	241	0.4006
-3	27	41.5878	37	99	5.87359	77	171	1.29078	117	243	0.38991
-2	28	39.8239	38	100	5.62961	78	172	1.25423	118	244	0.37956
-1	30	37.1988	39	102	5.39689	79	174	1.2133	119	246	0.36954
0	32	35.2024	40	104	5.17519	80	176	1.17393	120	248	0.35982
1	34	33.3269	41	106	4.96392	81	178	1.13604	121	250	0.35042
2	36	31.5635	42	108	4.76253	82	180	1.09958	122	252	0.3413
3	37	29.9058	43	109	4.5705	83	181	1.06448	123	253	0.33246
4	39	28.3459	44	111	4.38736	84	183	1.03069	124	255	0.3239
5	41	26.8778	45	113	4.21263	85	185	0.99815	125	257	0.31559
6	43	25.4954	46	115	4.04589	86	187	0.96681	126	259	0.30754
7	45	24.1932	47	117	3.88673	87	189	0.93662	127	261	0.29974
8	46	22.5662	48	118	3.73476	88	190	0.90753	128	262	0.29216
9	48	21.8094	49	120	3.58962	89	192	0.8795	129	264	0.28482
10	50	20.7184	50	122	3.45097	90	194	0.85248	130	266	0.2777
11	52	19.6891	51	124	3.31847	91	196	0.82643	131	268	0.27078
12	54	18.7177	52	126	3.19183	92	198	0.80132	132	270	0.26408
13	55	17.8005	53	127	3.07075	93	199	0.77709	133	271	0.25757
14	57	16.9341	54	129	2.95896	94	201	0.75373	134	273	0.25125
15	59	16.1156	55	131	2.84421	95	203	0.73119	135	275	0.24512
16	61	15.3418	56	133	2.73823	96	205	0.70944	136	277	0.23916
17	63	14.6181	57	135	2.63682	97	207	0.68844	137	279	0.23338
18	64	13.918	58	136	2.53973	98	208	0.66818	138	280	0.22776
19	66	13.2631	59	138	2.44677	99	210	0.64862	139	282	0.22231

**Appendix 2** Temperature Sensor Resistance Value Table for T5 (°C --K)

°C	°F	K Ohm	°C	°F	K Ohm	°C	°F	K Ohm	°C	°F	K Ohm
-20	-4	542.7	20	68	68.66	60	140	13.59	100	212	3.702
-19	-2	511.9	21	70	65.62	61	142	13.11	101	214	3.595
-18	0	483	22	72	62.73	62	144	12.65	102	216	3.492
-17	1	455.9	23	73	59.98	63	145	12.21	103	217	3.392
-16	3	430.5	24	75	57.37	64	147	11.79	104	219	3.296
-15	5	406.7	25	77	54.89	65	149	11.38	105	221	3.203
-14	7	384.3	26	79	52.53	66	151	10.99	106	223	3.113
-13	9	363.3	27	81	50.28	67	153	10.61	107	225	3.025
-12	10	343.6	28	82	48.14	68	154	10.25	108	226	2.941
-11	12	325.1	29	84	46.11	69	156	9.902	109	228	2.86
-10	14	307.7	30	86	44.17	70	158	9.569	110	230	2.781
-9	16	291.3	31	88	42.33	71	160	9.248	111	232	2.704
-8	18	275.9	32	90	40.57	72	162	8.94	112	234	2.63
-7	19	261.4	33	91	38.89	73	163	8.643	113	235	2.559
-6	21	247.8	34	93	37.3	74	165	8.358	114	237	2.489
-5	23	234.9	35	95	35.78	75	167	8.084	115	239	2.422
-4	25	222.8	36	97	34.32	76	169	7.82	116	241	2.357
-3	27	211.4	37	99	32.94	77	171	7.566	117	243	2.294
-2	28	200.7	38	100	31.62	78	172	7.321	118	244	2.233
-1	30	190.5	39	102	30.36	79	174	7.086	119	246	2.174
0	32	180.9	40	104	29.15	80	176	6.859	120	248	2.117
1	34	171.9	41	106	28	81	178	6.641	121	250	2.061
2	36	163.3	42	108	26.9	82	180	6.43	122	252	2.007
3	37	155.2	43	109	25.86	83	181	6.228	123	253	1.955
4	39	147.6	44	111	24.85	84	183	6.033	124	255	1.905
5	41	140.4	45	113	23.89	85	185	5.844	125	257	1.856
6	43	133.5	46	115	22.89	86	187	5.663	126	259	1.808
7	45	127.1	47	117	22.1	87	189	5.488	127	261	1.762
8	46	121	48	118	21.26	88	190	5.32	128	262	1.717
9	48	115.2	49	120	20.46	89	192	5.157	129	264	1.674
10	50	109.8	50	122	19.69	90	194	5	130	266	1.632
11	52	104.6	51	124	18.96	91	196	4.849			
12	54	99.69	52	126	18.26	92	198	4.703			
13	55	95.05	53	127	17.58	93	199	4.562			
14	57	90.66	54	129	16.94	94	201	4.426			
15	59	86.49	55	131	16.32	95	203	4.294			
16	61	82.54	56	133	15.73	96	205	4.167			
17	63	78.79	57	135	15.16	97	207	4.045			
18	64	75.24	58	136	14.62	98	208	3.927			
19	66	71.86	59	138	14.09	99	210	3.812			

## 2.Compressor checking

Measure the resistance value of each winding by using the tester.

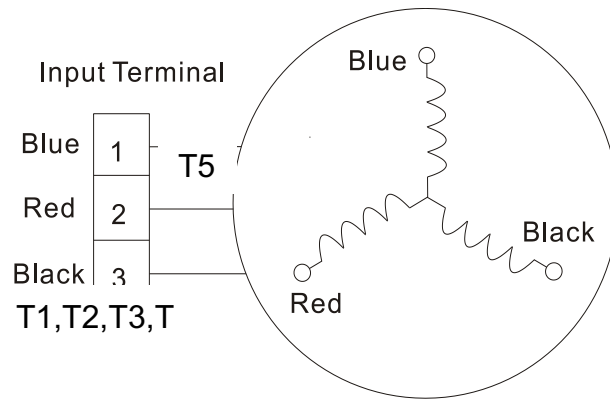

Position	Resistance Value		
	KSN98D22UFZ	KSM135D23UFZ	KTF235D22UMT
Blue - Red	1.57Ω (20°C/68°F)	1.72Ω (20°C/68°F)	0.75Ω (20°C/68°F)
Blue - Black			
Red - Blue			







# AIR CONDITIONING SYSTEMS

## WALL MOUNTED UNIT



Scan here to download the latest version of this manual.

